



System No. WW-D-0028

July 25, 2002

Assembly Rating — 2 Hr

Nominal Joint Width - 1 in. max

Class II and III Movement Capabilities - 12.5% Compression and Extension

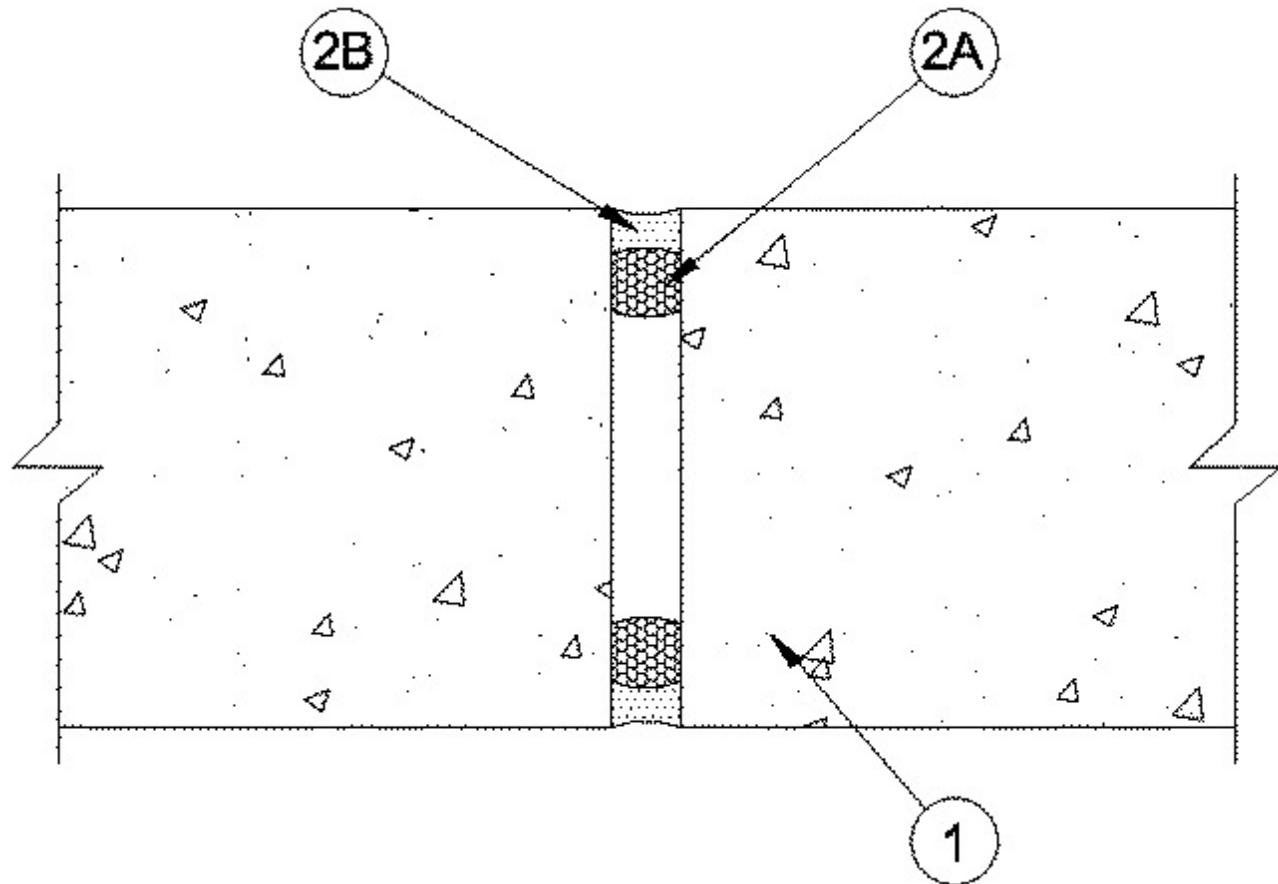

1. **Wall Assembly** — Min 4-1/2 in. thick lightweight or normal weight (100-150 pcf) concrete wall. Wall may also be constructed of any UL Classified **Concrete Blocks***.

See **Concrete Blocks** (CAZT) category in the Fire Resistance Directory for names of manufacturers.

2. **Joint System** — Max width of joint (at time of installation) is 1 in. The joint system is designed to accommodate a max 12.5% compression or extension from its installed width. The joint system shall consist of the following:

A. **Packing Material** — Foam backer rod firmly packed into opening as a permanent form on both sides of wall. Packing material to be recessed from both surfaces of wall to accommodate the required thickness of fill material.

B. **Fill, Void or Cavity Material*** — Min 1/2 in. thickness of fill material applied within the joint, flush with each surface of wall.

RECTORSEAL — MC 150+ Caulk

*Bearing the UL Classification Mark