



System No. W-L-1102

May 13, 2004

F Rating — 2 Hr

T Rating — 0 Hr

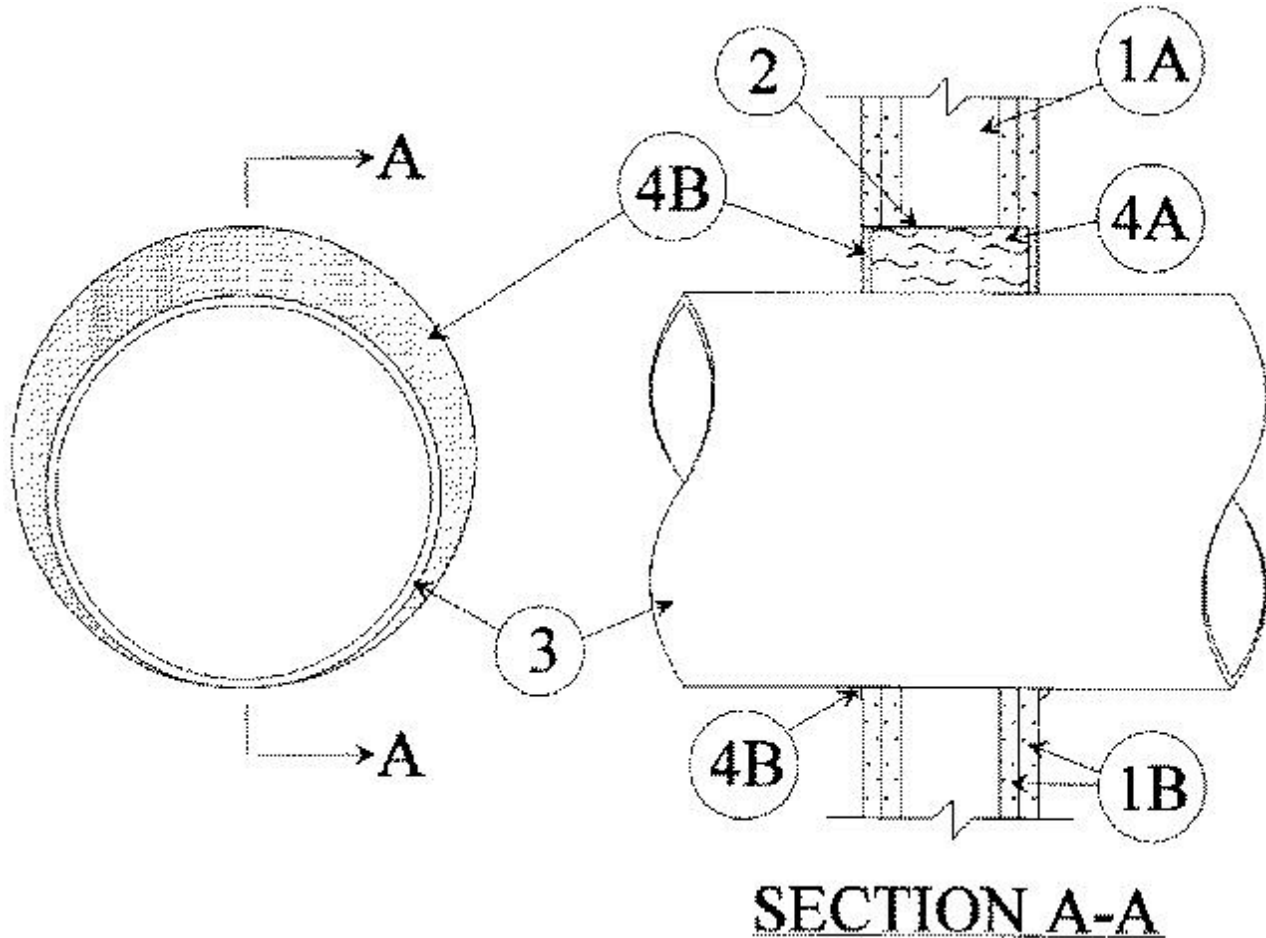

SECTION A-A

1. Wall Assembly — The fire-rated gypsum wallboard/stud wall assembly shall be constructed of the materials and in the manner specified in the individual U300 or U400 Series Wall and Partition Designs in the UL Fire Resistance Directory and shall include the following construction features:

A. Studs — Wall framing may consist of either wood studs or steel channel studs. Wood studs to consist of nom 2 by 4 in. lumber spaced 16 in. OC. Steel studs to be min 2-1/2 in. wide and spaced max 24 in. OC.

B. Gypsum Board* — Two layers of nom 5/8 in. thick gypsum wallboard, as specified in the individual Wall and Partition Design. Max diam of opening is 11-3/4 in.

2. Steel Wire Mesh — Cylindrical sleeve fabricated from No. 8 steel wire mesh and having a min 1 in. lap along the longitudinal seam. Steel wire mesh to be centered and formed to fit periphery of through opening. Length of steel wire mesh to be equal to the thickness of the wall.

3. Through Penetrants — One metallic pipe, conduit or tubing to be installed either concentrically or eccentrically within the firestop system. Pipe, conduit or tubing to be rigidly supported on both sides of wall assembly. The following types and sizes of metallic pipes, conduits or tubing may be used:

A. Steel Pipe — Nom 10 in. diam (or smaller) Schedule 20 (or heavier) steel pipe. The annular space shall be min 0 in. to max 1 in.

B. Iron Pipe — Nom 10 in. diam (or smaller) cast or ductile iron pipe. The annular space shall be min 0 in. to max 1 in.

C. Conduit — Nom 2 in. diam (or smaller) electrical metallic tubing or steel conduit. The annular space shall be min 0 in. to max 1 in.

D. Copper Tubing — Nom 2 in. diam (or smaller) Type L (or heavier) copper tubing. The annular space shall be min 0 in. to max 1 in.

E. Copper Pipe — Nom 2 in. diam (or smaller) Regular (or heavier) copper pipe. The annular space shall be min 0 in. to max 1 in.

4. Firestop System — The firestop system shall consist of the following:

A. Packing Material — Min 4-1/2 in. thickness of min 4.0 pcf mineral wool batt insulation firmly packed into opening as a permanent form. Packing material to be recessed from both surfaces of wall as required to accommodate the required thickness of fill material.

B. Fill, Void or Cavity Material* — Caulk — Min 1/4 in. thickness of fill material applied within the annulus, flush with both surfaces of wall. At the point contact location between pipe and wall, a min 1/4 in. diam bead of fill material shall be applied at the wall/pipe interface on both surfaces of wall.

RECTORSEAL — Metacaulk 1000

*Bearing the UL Classification Mark