



System No. W-L-1024

November 29, 1995

(Formerly System No. 428)

F Rating — 2 Hr

T Rating — 0 Hr

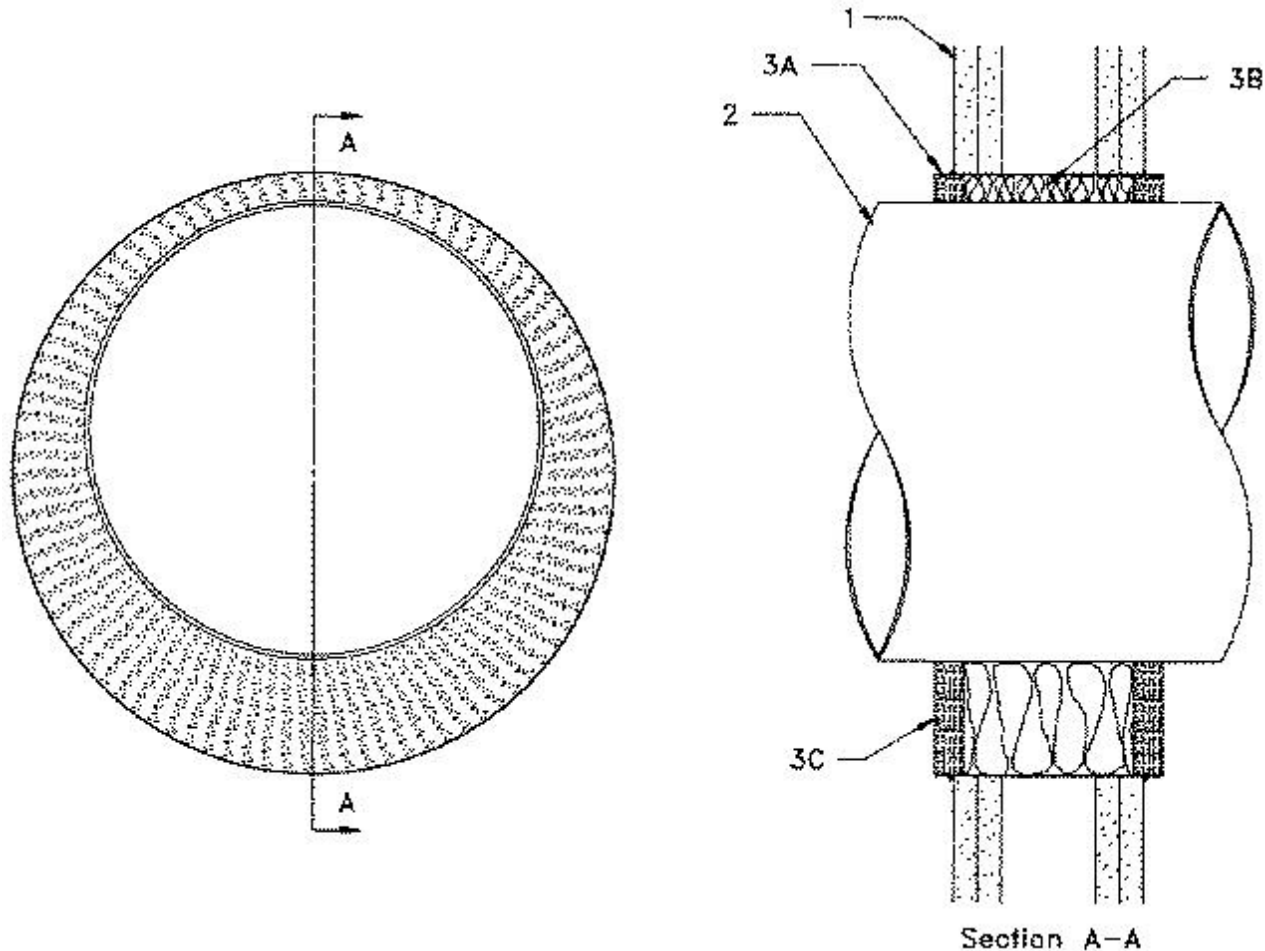

1. **Wall Assembly** — The fire-rated gypsum wallboard/stud wall assembly shall be constructed of the materials and in the manner specified in the individual U300 or U400 Series Wall and Partition Designs in the UL Fire Resistance Directory and shall include the following construction features:

A. **Studs** — Wall framing may consist of either wood studs or steel channel studs. Wood studs to consist of nom 2 by 4 in. lumber spaced 16 in. OC. Steel studs to be min 2-1/2 in. wide and spaced max 24 in. OC.

B. **Gypsum Board*** — Two layers of nom 5/8 in. thick gypsum wallboard, as specified in the individual Wall and Partition Design. Max diam of opening is 14-1/2 in. for wood stud walls and 18-3/4 in. for steel stud walls.

2. **Through Penetrants** — One metallic pipe or tubing to be installed either concentrically or eccentrically within the firestop system. Pipe or tubing to be rigidly supported on both sides of wall assembly. The annular space shall be min 3/4 in. to max 3 in. The following types and sizes of metallic pipes or tubing may be used:

A. **Steel Pipe** — Nom 12 in. diam (or smaller) Schedule 10 (or heavier) steel pipe.

B. **Copper Tubing** — Nom 4 in. diam (or smaller) Type L (or heavier) copper tubing.

3. Firestop System — The firestop system shall consist of the following:

A. **Metallic Sleeve** — Cylindrical sleeve fabricated from 0.028 in. thick (24 gauge) galv sheet steel and having a min 1 in. lap along the longitudinal seam. Length of steel sleeve to be 1 in. more than the overall thickness of the wall such that, when installed in circular opening, the ends of the sleeves project 1/2 in. from each surface of the wall. The diam of the openings cut in the gypsum wallboard layers on each side of the wall assembly to be 1-1/2 to 6 in. larger than outside diam of pipe such that, when the sleeve is installed, a 3/4 to 3 in. annular space will be present between the steel sleeve and the pipe around the entire circumference of the pipe. Sleeve installed by coiling the sheet steel to a diam smaller than the through opening, inserting the coil through the openings and releasing the coil to let it uncoil against the circular cutouts in the gypsum wallboard layers.

B. **Packing Material** — Min 4-1/2 in. thickness of min 4.4 pcf mineral wool batt insulation firmly packed into opening as a permanent form. Packing material to be recessed from both surfaces of wall as required to accommodate the required thickness of fill material.

C. **Fill, Void or Cavity Material*** — **Caulk** — Min 3/4 in. thickness of tightly packed fill material applied within the annulus, flush with the ends of the steel sleeve. Additional fill material to be installed to the outer perimeter of the steel sleeve at its egress from the opening.

RECTORSEAL — Metacaulk 950

*Bearing the UL Classification Mark