



### System No. W-J-5160

May 07, 2015

F Rating — 2 Hr

T Rating — 1 Hr

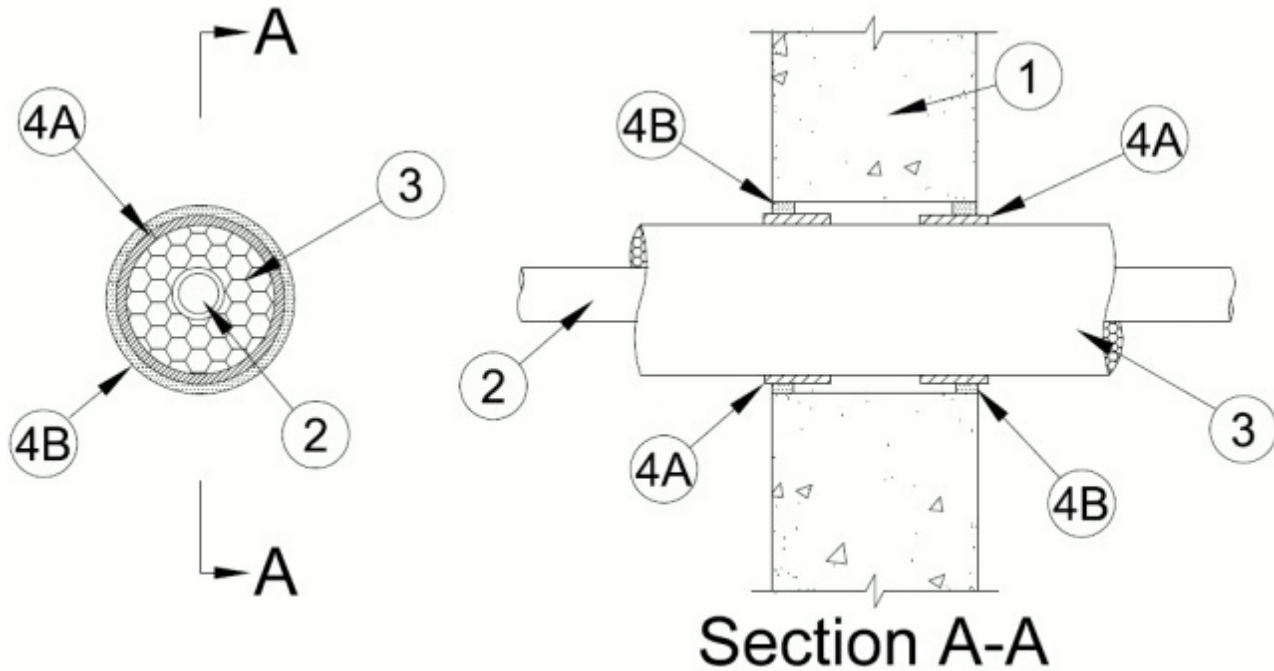

1. **Wall Assembly** — Min 6 in. (152 mm) thick lightweight or normal weight (100-150 pcf or 1600-2400 kg/m<sup>3</sup>) concrete. Wall may also be constructed of any UL Classified **Concrete Blocks\***. Diameter of the opening shall be max 1/2 in. (13 mm) larger than outer diameter (OD) of insulated penetrant. Max diam of opening is 4-1/2 in. (165 mm).

See **Concrete Blocks** (CAZT) category in the Fire Resistance Directory for names of manufacturers.

2. **Through Penetrants** — One tube centered within opening. Tube to be rigidly supported on both sides of wall assembly. The following types and sizes of metallic tubing may be used:

A. **Aluminum Tubing** — Reflok 6061-T4 ASTM B210 seamless aluminum tubing for use in closed (process or supply) piping systems. Tubing size shall be maximum 1-1/8 in. (29 mm) to minimum 1/4 in. (6 mm) outer diameter (OD) having wall thickness ranging from 0.050 in. (1.3 mm) to 0.030 in. (0.8 mm) respectively.

3. **Pipe Covering** — The following pipe covering shall be used with each Through Penetrant (Item 2).

A. **Tube Insulation-Plastics+** — Nom 1/2 in. (13 mm) thick Aerocel Ethylene Propylene Diene Terpolymer (EPDM) pipe insulation furnished in the form of tubing. The annular space between the insulated penetrant and the edge of the opening shall not exceed 5/8 in. (16 mm).

See **Plastics+** - (QMFZ2) category in the Plastics Recognized Component Directory for names of manufacturers. Any Recognized Component tube insulation material meeting the above specifications of having a UL 94 Flammability Classification of 94-5VA may be used.

4. **Firestop System** — The firestop system shall consist of the following:

A. **Fill, Void or Cavity Material\* - Wrap Strip** — One layer of nom 1/4 in. (6 mm) thick by 2 in. (51 mm) wide intumescent wrap strip wrapped around the outer circumference of the insulated

pipe on each side of the wall. Wrap strip installed with butted seam and located within the annular space such that edge of wrap strip projects nom 1/4 in. (6 mm) beyond face of wall at both sides of wall. Wrap strip temporarily secured with tape or tie wire.

**RECTORSEAL** — Metacaulk Wrap Strip, Biostop Wrap Strip or Flamesafe Wrap Strip

**B. Fill, Void or Cavity Material\*—Sealant** — Min 5/8 in. (16 mm) thickness of fill material applied within the annulus between wrap strip and periphery of opening, flush with both surfaces of wall.

**RECTORSEAL** — Metacaulk 1000, Biostop 500+, FlameSafe FS1900

\* Indicates such products shall bear the UL or cUL Certification Mark for jurisdictions employing the UL or cUL Certification (such as Canada), respectively.