



System No. W-J-2124

June 03, 2011

F Rating — 2 Hr

T Rating — 1-1/2 Hr

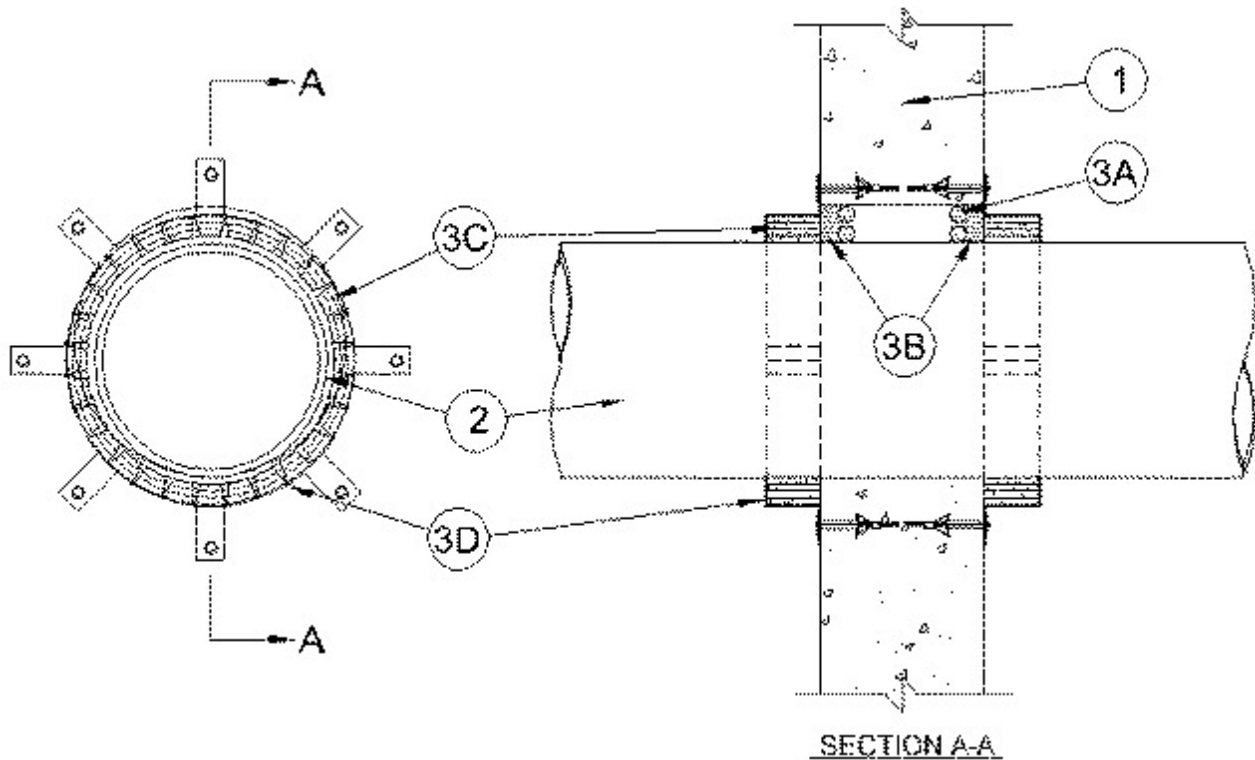

1. **Wall Assembly** — Min 6 in. (152 mm) thick lightweight or normal weight (100-150 pcf or 16000-2400 kg/m³) concrete wall assembly. Wall may also be constructed of any UL Classified Concrete Blocks*. Max diam of opening is 5 in. (127 mm).

See **Concrete Blocks** (CAZT) category in the Fire Resistance Directory for names of manufacturers.

2. **Through Penetrants** — One nonmetallic pipe to be installed either eccentrically or concentrically within the firestop system. The annular space shall be min 0 in. (point contact) to max 1/2 in. (13 mm). Pipe to be rigidly supported on both sides of wall assembly. The following types and sizes of nonmetallic pipes may be used:

A. **Polyvinyl Chloride (PVC) Pipe** — Nom 4 in. (102 mm) diam (or smaller) Schedule 40 solid core PVC pipe for use in closed (process or supply) or vented (drain, waste or vent) piping systems.

B. **Chlorinated Polyvinyl Chloride (CPVC) Pipe** — Nom 4 in. (102 mm) diam (or smaller) SDR 13.5 or Schedule 40 CPVC pipe for use in closed (process or supply) piping systems. Schedule 40 CPVC pipe for use in vented (drain, waste or vent) piping systems.

C. **Acrylonitrile Butadiene Styrene (ABS) Pipe** — Nom 4 in. (102 mm) diam (or smaller) Schedule 40 cellular or solid core ABS pipe for use in closed (process or supply) or vented (drain, waste or vent) piping systems.

3. **Firestop System** — The firestop system shall consist of the following:

A. **Packing Material** — Foam backer rod firmly packed into opening as a permanent form. Packing material to be recessed from both surfaces of wall as required to accommodate the required thickness of fill material.

B. Fill, Void or Cavity Material* - Caulk — Min 1/4 in. (6 mm) thickness of fill material applied within the annulus, flush with both surfaces of wall.

RECTORSEAL — Metacaulk 1000

C. Fill, Void or Cavity Material* - Wrap Strip — Nom 1/4 in. (6 mm) thick by 1 in. (25 mm) wide intumescent wrap strip. When diameter of penetrant is 4 in. (102 mm), two layers of wrap strip are individually wrapped around the through-penetrant with ends butted and held in place with masking tape. Butted ends in successive layer shall be offset. When diameter of penetrant is equal to or less than 2 in. (51 mm), one layer of wrap strip is wrapped around the through-penetrant with ends butted and held in place with masking tape. Wrap strips butted tightly against both surface of wall.

RECTORSEAL — Metacaulk Wrap Strip

D. Steel Collar — Collar fabricated from coils of precut min 0.016 in. (0.41 mm) thick (No. 28 gauge) galv steel available from fill material manufacturer. Collar shall be nom 1 in. (25 mm) deep with 1 in. (25 mm) wide by 1-1/2 in. (38 mm) long anchor tabs on 4 in. (102 mm) centers for securement to surfaces of wall. In addition, collar contains retainer tabs, 1/4 in. (6 mm) wide by 3/8 in. (10 mm) long, located opposite the anchor tabs. The collar shall be wrapped over the wrap strip with the overlapping end of the collar cut even with the end of an anchor tab and overlapping the other end of the collar by 1 in. (25 mm) Collar secured to both surfaces of wall at each anchor tab by means of min 1/4 in. (6 mm) diam by 1-1/2 in. (38 mm) long steel expansion bolts or Tapcon® concrete anchors in conjunction with 1/4 in. (6 mm) by 5/8 in. (16 mm) diam washers.

*Bearing the UL Classification Mark