



System No. W-J-1081

May 13, 2004

F Rating — 2 Hr

T Rating — 2 Hr

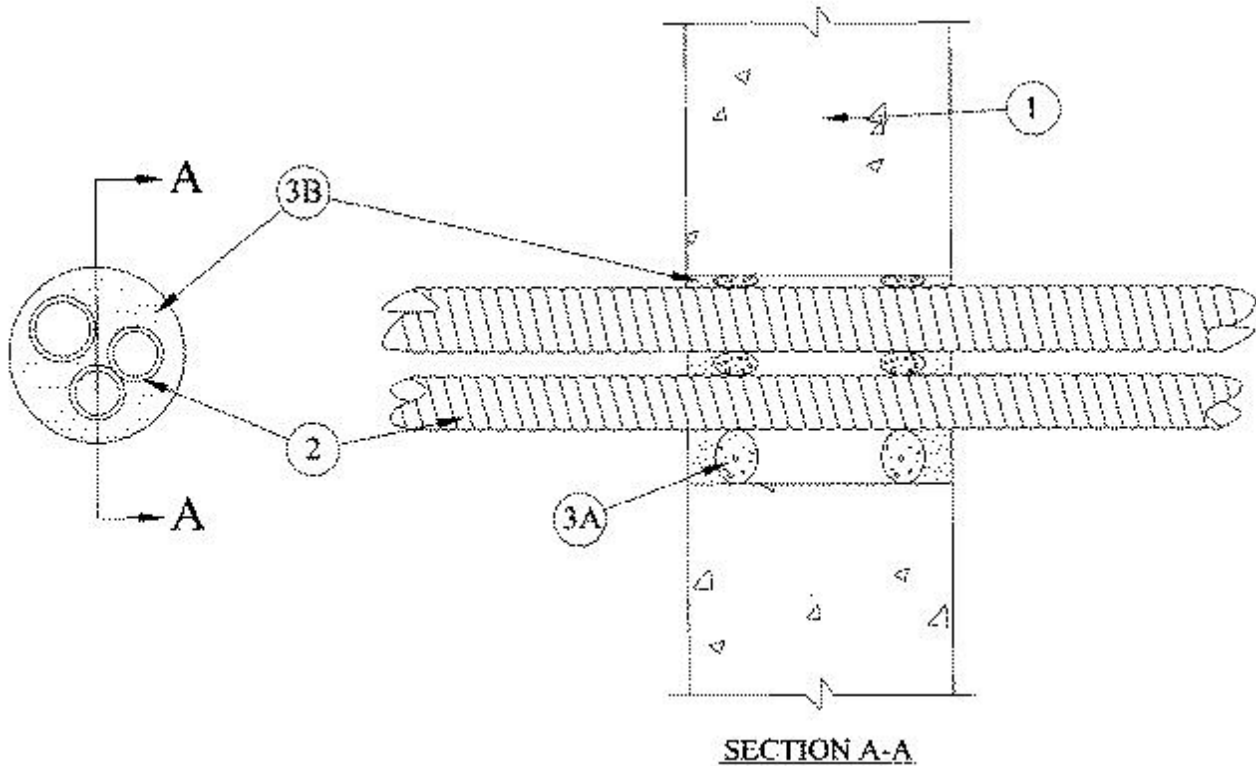

1. **Wall Assembly** — Min 6 in. thick reinforced lightweight or normal weight (100-150 pcf) concrete. Wall may also be constructed of any UL Classified **Concrete Blocks***. Max diam of opening is 4 in.

See **Concrete Blocks** (CAZT) category in the Fire Resistance Directory for names of manufacturers.

1A. **Metallic Sleeve** — (Optional) — Cylindrical sleeve fabricated from min No. 26 gauge galv sheet steel and having a min 1 in. overlap along the longitudinal seam. Ends of sleeve to be flush with or extend a max 1 in. beyond each surface of wall.

2. **Through Penetrating Product*** — **Flexible Metal Piping** — A max of three nom 1-1/4 in. diam (or smaller) steel flexible metal piping to be installed within the firestop system. The annular space between pipes shall be min 3/8 in. to max 1/2 in. The annular space between pipes and periphery of opening shall be min 1/4 in. to max 1-1/2 in. Pipes to be rigidly supported on both sides of wall assembly.

OMEGA FLEX INC

GASTITE, DIV OF TITFLEX

WARD MFG INC

3. **Firestop System** — The firestop system shall consist of the following:

A. **Packing Material** — Foam backer rod firmly packed into opening as a permanent form. Packing material to be recessed from both surfaces of wall as required to accommodate the required thickness of fill material.

B. Fill, Void or Cavity Material* — Caulk — Min 1/2 in. thickness of fill material applied within the annulus, flush with both surfaces of wall.

RECTORSEAL — Metacaulk 1000

*Bearing the UL Classification Mark