

### System No. HW-S-0080

April 22, 2011

Assembly Ratings — 1 and 2 Hr (See Items 1 and 2)

Maximum Joint Width — 1 In.

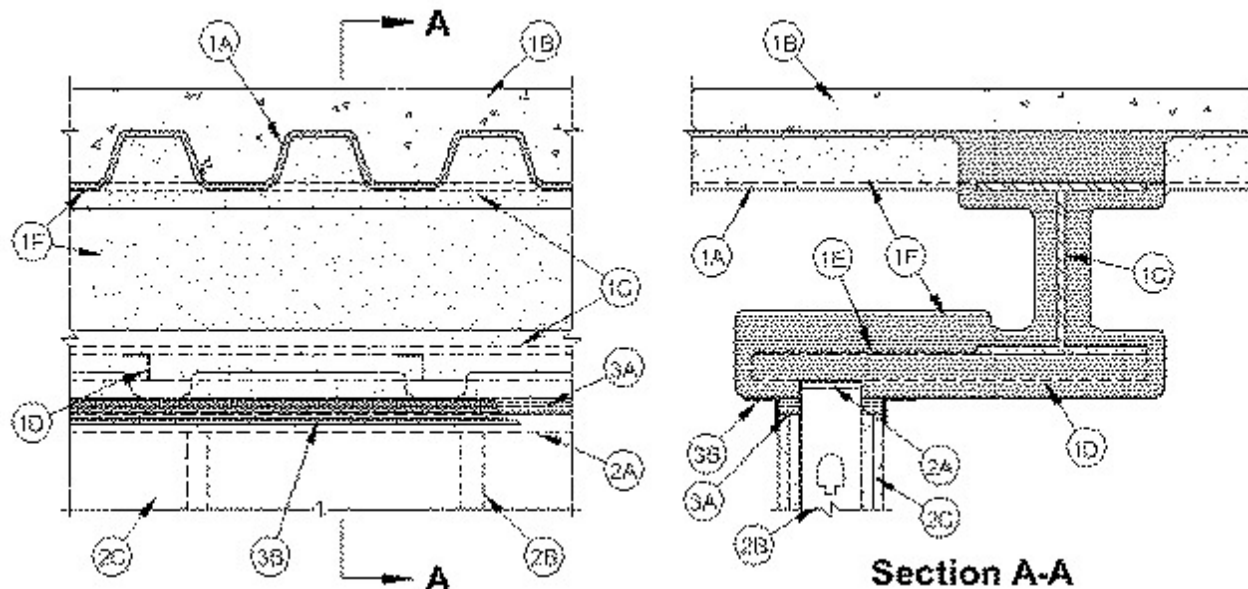

1. **Floor Assembly** — The fire-rated fluted steel deck/concrete floor assembly shall be constructed of the materials and in the manner described in the individual D700 or D900 Series Floor-Ceiling Design in the UL Fire Resistance Directory and shall include the following construction features:

A. **Steel Floor And Floor Units\*** — Max 3 in. (76 mm) deep galv steel fluted floor units.

B. **Concrete** — Min 2-1/2 in. (64 mm) thick reinforced concrete, as measured from the top plane of the floor units.

C. **Structural Steel Support** — Steel beam, as specified in the individual D700 or D900 Series Floor-Ceiling Design, used to support steel floor units. Steel beam parallel with wall assembly.

D. **Steel Furring** — Z-shaped bars or channels, located to span from steel beam to min 1 in. (25 mm) beyond face of wall and spaced max 24 in. (610 mm) on center. Z-shaped bars are nom 1-1/2 to 2 in. (38 to 51 mm) deep and formed from min 16 gauge painted or galvanized steel. Channels are nom 1-1/2 in. (38 mm) or 2 in. (51 mm) deep and formed from min 16 gauge painted or galvanized steel. Each bar or channel welded to steel beam and welded, bolted or screwed to ceiling runner of wall. Each bar or channel shall be fully covered with spray applied fire resistive material (Item 1F) to the minimum thickness of material required on the flanges of the steel beam.

E. **Steel Lath** — Nom 3/8 in. (10 mm) diamond mesh expanded steel rib lath having a nom weight of 3.4 lb/yd<sup>2</sup> (1.8 kg/m<sup>2</sup>) shall be installed over and attached to the steel furring bars or channels (Item 1D) to completely cover the exposed area from the flange tip of the steel beam to the end of the bar/channel framing extending beyond the wall surface. The lath shall be secured with steel fasteners or tie wire and shall be fully covered with spray applied fire resistive material (Item 1F).

F. **Spray-Applied Fire Resistive Material\*** — After installation of steel furring and steel lath (Items 1D and 1E), steel floor units and structural steel support to be sprayed with the min thickness of material specified in the individual D700 or D900 Series Design. The flutes of the steel floor units are to be filled with material across the entire top flange of the steel beam. Each bar or channel furring member (Item 1D) shall be fully covered with spray applied fire resistive material to the minimum thickness of material required on the flanges of the steel beam. The

thickness of material applied to the expanded steel lath shall be sufficient to completely fill the spaces between the bar/channel furring above the wall. **Additional material shall be applied to the web of the steel beam on each side of the wall. The min total thickness of material applied to each side of the steel beam web shall be 13/16 in. (21 mm) for 1 hr fire rated assemblies and 1-3/8 in. (35 mm) for 2 hr fire rated assemblies.** For D700 Series Designs, all surfaces of the steel floor units to be sprayed with the thickness of material specified in the individual D700 Series Design. For D900 Series Designs structural steel supports, steel furring and steel lath only to be sprayed in accordance with the specifications in the individual D900 Series Design.

**W R GRACE & CO - CONN** — Type MK-6/HY, MK-6/HYES, MK-65 and RG

**F1. Spray-Applied Fire Resistive Material\*** — After installation of steel furring and steel lath (Items 1D and 1E), steel floor units and structural steel support to be sprayed with the min thickness of material specified in the individual D700 or D900 Series Design. The flutes of the steel floor units are to be filled with material across the entire top flange of the steel beam. Each bar or channel furring member (Item 1D) shall be fully covered with spray applied fire resistive material to the minimum thickness of material required on the flanges of the steel beam. The thickness of material applied to the expanded steel lath shall be sufficient to completely fill the spaces between the bar/channel furring above the wall. **Additional material shall be applied to the web of the steel beam on each side of the wall. The min total thickness of material applied to each side of the steel beam web shall be 11/16 in. (18 mm) for 1 hr fire rated assemblies and 1-1/2 in. (38 mm) for 2 hr fire rated assemblies.** For D700 Series Designs, all surfaces of the steel floor units to be sprayed with the thickness of material specified in the individual D700 Series Design. For D900 Series Designs structural steel supports, steel furring and steel lath only to be sprayed in accordance with the specifications in the individual D900 Series Design.

**ISOLATEK INTERNATIONAL** — Type 300

**The hourly fire rating of the floor assembly shall be equal to or greater than the hourly fire rating of the wall assembly.**

**1A. Roof Assembly — (Not Shown)** — As an alternate to the floor assembly, a fire-rated fluted steel deck roof assembly may be used. The roof assembly shall be constructed of the materials and in the manner described in the individual P900 or P700 Series Roof-Ceiling Design in the UL Fire Resistance Directory. The roof assembly shall include the following construction features:

**A. Steel Roof Deck** — Max 3 in. (76 mm) deep galv steel fluted roof deck.

**B. Roof Insulation** — For P900 Series Designs, min 2-1/4 in. (57 mm) thick poured insulating concrete, as measured from the top plane of the roof deck. For P700 Series Designs, roof insulation shall be as specified in the individual design.

**C. Structural Steel Support** — Steel beam, as specified in the individual P700 or P900 Series Floor-Ceiling Design, used to support steel floor units. Steel beam parallel with wall assembly.

**D. Steel Furring** — Z-shaped bars or channels, located to span from steel beam to min 1 in. (25 mm) beyond face of wall and spaced max 24 in. (610 mm) on center. Z-shaped bars are nom 1-1/2 to 2 in. (38 to 51 mm) deep and formed from min 16 gauge painted or galvanized steel. Channels are nom 1-1/2 in. (38 mm) or 2 in. (51 mm) deep and formed from min 16 gauge painted or galvanized steel. Each bar or channel welded to steel beam and welded, bolted or screwed to ceiling runner of wall. Each bar or channel shall be fully covered with spray applied fire resistive material to the minimum thickness of material required on the flanges of the steel beam.

**E. Steel Lath** — Nom 3/8 in. (10 mm) diamond mesh expanded steel rib lath having a nom weight of 3.4 lb/yd<sup>2</sup> (1.8 kg/m<sup>2</sup>) shall be installed over and attached to the steel furring bars or channels (Item 1AD) to completely cover the exposed area from the flange tip of the steel beam to the end of the bar/channel framing extending beyond the wall surface. The lath shall be secured with steel fasteners or tie wire and shall be fully covered with spray applied fire resistive material (Item 1AF).

**F. Spray-Applied Fire Resistive Material\*** — After installation of steel furring and steel lath (Items 1AD and 1AE) surfaces of the roof deck to be sprayed with the thickness of material specified in the individual P700 Series Design. For P900 Series Designs structural steel supports, steel furring and steel lath only to be sprayed in accordance with the specifications in the individual P900 Series Design. The flutes of the steel roof deck are to be filled with material

across the entire top flange of the steel beam. Each bar or channel furring member (Item 1AD) shall be fully covered with spray applied fire resistive material to the minimum thickness of material required on the flanges of the steel beam. The thickness of material applied to the expanded steel lath shall be sufficient to completely fill the spaces between the bar/channel furring above the wall. **Additional material shall be applied to the web of the steel beam on each side of the wall. The min total thickness of material applied to each side of the steel beam web shall be 13/16 in. (21 mm) for 1 hr fire rated assemblies and 1-3/8 in. (35 mm) for 2 hr fire rated assemblies.**

**W R GRACE & CO - CONN** — Type MK-6/HY, MK-6/HY ES, RG and MK-6S

**F1. Spray-Applied Fire Resistive Material\*** — After installation of steel furring and steel lath (Items 1AD and 1AE) surfaces of the roof deck to be sprayed with the thickness of material specified in the individual P700 Series Design. For P900 Series Designs structural steel supports, steel furring and steel lath only to be sprayed in accordance with the specifications in the individual P900 Series Design. The flutes of the steel roof deck are to be filled with material across the entire top flange of the steel beam. Each bar or channel furring member (Item 1AD) shall be fully covered with spray applied fire resistive material to the minimum thickness of material required on the flanges of the steel beam. The thickness of material applied to the expanded steel lath shall be sufficient to completely fill the spaces between the bar/channel furring above the wall. **Additional material shall be applied to the web of the steel beam on each side of the wall. The min total thickness of material applied to each side of the steel beam web shall be 11/16 in. (18 mm) for 1 hr fire rated assemblies and 1-1/2 in. (38 mm) for 2 hr fire rated assemblies.**

**ISOLATEK INTERNATIONAL** — Type 300

**The hourly fire rating of the roof assembly shall be equal or greater than the hourly fire rating of the wall assembly.**

**2. Wall Assembly** — The 1 or 2 hr fire rated gypsum board/steel stud wall assembly shall be constructed of the materials and in the manner described in the individual U400 or V400 Series Wall and Partition Design in the UL Fire Resistance Directory and shall include the following construction features:

**A. Steel Floor and Ceiling Runners** — Floor and ceiling runners of wall assembly shall consist of galv steel channels sized to accommodate steel studs (Item 2B). Ceiling runner to be provided with min 1-1/4 in. (32 mm) to max 3 in. (76 mm) flanges. Ceiling runner is secured to steel furring (Item 1D) with steel fasteners or welds spaced max 24 in. (610 mm) OC. Ceiling runner to be installed parallel with structural steel support and located such that a max clearance of 12 in. (305 mm) is present between the finished wall and the flange of the steel beam (Item 1C).

**B. Studs** — Steel studs to be min 3-1/2 in. (89 mm) wide. Studs cut 1/2 in. to 3/4 in. (13 to 19 mm) less in length than assembly height with bottom nesting in and secured to floor runner. Studs to nest in ceiling runner without attachment.

**C. Gypsum Board\*** — Gypsum board sheets installed to a min total 5/8 in. (16 mm) or 1-1/4 in. (32 mm) thickness on each side of wall for 1 and 2 hr fire rated assemblies, respectively. Wall to be constructed as specified in the individual U400 or V400 Series Design in the UL Fire Resistance Directory except that a max 1 in. (25 mm) gap shall be maintained between the top of the gypsum board and the bottom plane of the spray applied fire resistive material on the steel furring (Item 1D) on both sides of the wall assembly.

**The hourly fire rating of the joint system is equal to the hourly fire rating of the wall.**

**3. Joint System** — Max separation between bottom plane of spray-applied fire resistive material on the steel furring (Item 1D) and the top of the gypsum board is 1 in. (25 mm). The joint system shall consist of forming and fill materials, as follows:

**A. Forming Material\*** — Nom 4 pcf (64 kg/m<sup>3</sup>) density mineral wool batt insulation. Sections of mineral wool batt cut to a thickness equal to the overall thickness of gypsum board and compressed a min of 50 percent into the gap between the top of the gypsum board and the bottom plane of the spray applied fire resistive material on the steel furring (Item 1D) on both sides of the wall assembly.

**FIBREX INSULATIONS INC** — FBX Safing Insulation

**IIG MINWOOL L L C** — MinWool-1200 Safing

**ROCK WOOL MANUFACTURING CO** — Delta Safing Insulation

**ROCKWOOL MALAYSIA SDN BHD** — SAF Mineral Wool

**ROXUL INC** — SAF Mineral Wool

**THERMAFIBER INC** — Type SAF

**B. Fill, Void or Cavity Material\* - Sealant** — A min 1/8 in. (3 mm) wet thickness (min 1/16 in. or 1.6 mm dry thickness) of fill material sprayed or troweled on each side of wall to completely cover mineral wool forming material and to overlap min 1/2 in. (13 mm) onto wall and min 2 in. (51 mm) onto spray-applied fire resistive material.

**RECTORSEAL** — FlameSafe 3000, Metacaulk 1500 or Biostop 800 Spray

**3A. Joint System** — (Not Shown)— As an alternate to mineral wool and FlameSafe 3000 the following may be used. Max separation between bottom plane of spray-applied fire resistive material on the steel furring (Item 1D) and the top of the gypsum board is 1 in. (25 mm). The joint system shall consist of packing and fill materials, as follows:

**A. Packing Material** — (Not Shown) — Optional in 2 hr fire rated assemblies, foam backer rod friction fitted into joint opening and recessed to accommodate the required thickness of fill material.

**B. Fill, Void or Cavity Material\* — Sealant** — (Not Shown)— Min 5/8 in. thickness of fill material applied on each side of wall between the top of the gypsum board and spray-applied fire resistive material on the steel furring (Item 1D), flush with each surface of the wall. Bond breaker tape shall be applied to the ceiling runner (Item 2A) prior to the installation of fill material on both sides of the wall in 1 hr fire rated wall assemblies and in 2 hr fire rated wall assemblies where optional backer rod is not used.

**RECTORSEAL** — FS 1900 Sealant

\*Bearing the UL Classification Mark