

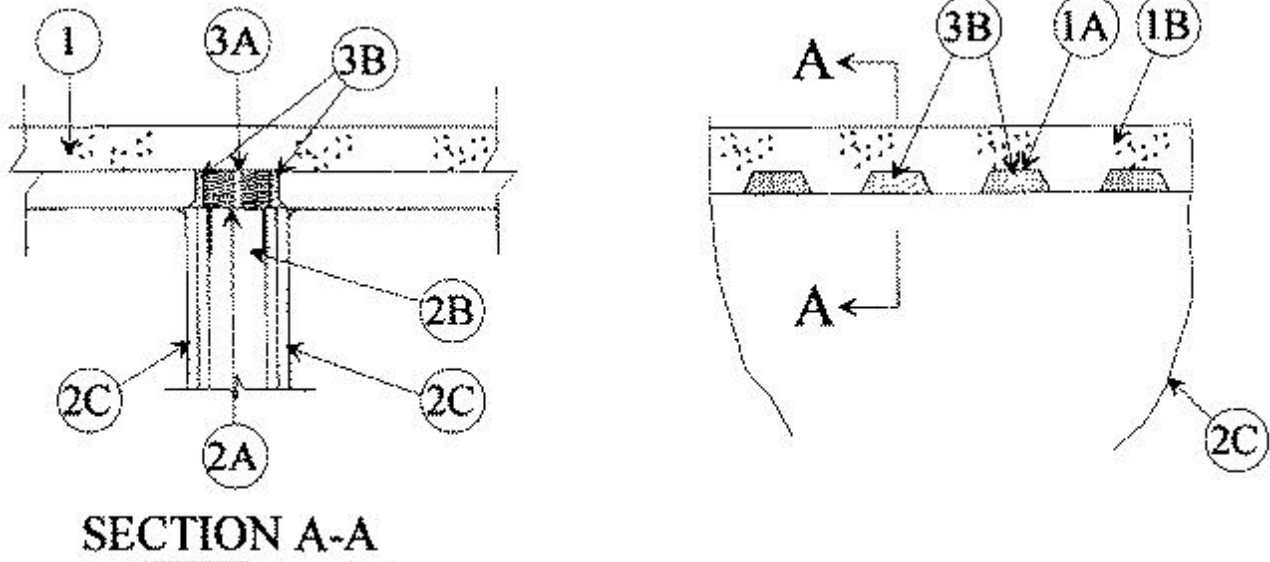

System No. HW-S-0023

November 05, 1997

Assembly Ratings — 1 and 2 Hr (See Item 2)



1. Floor Assembly — The fire rated fluted steel deck/concrete floor assembly shall be constructed of the materials and in the manner described in the individual Floor-Ceiling Design in the UL Fire Resistance Directory and shall include the following construction features:

A. Steel Floor and Form Units* — Composite or noncomposite max 3 in. deep min 22 galv or phos/painted fluted units. Adjacent units button-punched or welded together max 36 in. OC along side joints.

B. Normal Weight or Light Weight Concrete — Min 2-1/2 in. thick concrete of the type, density and compressive strength detailed for the specific Floor-Ceiling Design described in the UL Fire Resistance Directory.

2. Wall Assembly — The 1 or 2 Hr fire-rated gypsum wallboard/stud wall assembly shall be constructed of the materials and in the manner specified in the individual U400 Series Wall and Partition Designs in the UL Fire Resistance Directory and shall include the following construction features:

A. Steel Floor and Ceiling Runners — Floor and ceiling runners of wall assembly shall consist of min 25 ga galv steel channels sized to accommodate steel studs (Item 2B). Ceiling runner to be provided with min 1-1/4 in. flanges. Ceiling runner secured to valleys of steel floor units (Item 1A) with steel fasteners or by welds spaced max 24 in. OC.

B. Studs — Min 3-1/2 in. wide by 1-1/4 in. deep corrosion protected min 25 MSG steel channels. Steel stud spacing not to exceed 24 in. OC.

C. Gypsum Board* — 5/8 in. thick, 4 ft wide with square or tapered edges. Wallboard sheets installed vertically on both sides of stud framing with joints centered over studs. Wallboard to be butted tight to bottom of the steel deck. The gypsum wallboard type, thickness, number of layers and fastener types shall be as specified in the individual U400 Series Design in the UL Fire Resistance Directory.

3. Joint System — The joint system consists of a forming material and a fill material in the flutes of the steel floor units, as follows:

A. Packing Material — Min 3-3/4 in. thickness of min 4.0 pcf mineral wool batt insulation, tightly packed into flutes of the steel floor units between the top of the ceiling runner and bottom of the

steel floor units, and recessed from each surface of wall to accommodate the required thickness of fill material.

B. Fill, Void or Cavity Material* — Min 3/8 in. thickness of fill material installed on each side of the wall in the flutes of the steel floor units. An additional min 3/8 in. bead of fill material to be installed at the wallboard/steel deck interface.

RECTORSEAL — Metacaulk 835+

*Bearing the UL Classification Mark