

### System No. HW-D-0806

September 22, 2017

ANSI/UL2079	CAN/ULC S115
Assembly Ratings — 1 and 2 Hr (See Item 2)	F Ratings — 1 and 2 Hr (See Item 2)
Nominal Joint Width - 1/2 in.	FT Ratings — 1 and 2 Hr (See Item 2)
Class II or III Movement Capabilities — 50% Compression or 25% Extension	FH Ratings — 1 and 2 Hr (See Item 2)
L Rating at Ambient — Less than 1 CFM/Lin Ft	FTH Ratings — 1 and 2 Hr (See Item 2)
L Rating at 400°F — Less than 1 CFM/Lin Ft	Nominal Joint Width - 13 mm in.
	Class II or III Movement Capabilities — 50% Compression or 25% Extension
	L Rating at Ambient — Less than 1.55 L/s/m
	L Rating at 204 C— Less than 1.55 L/s/m

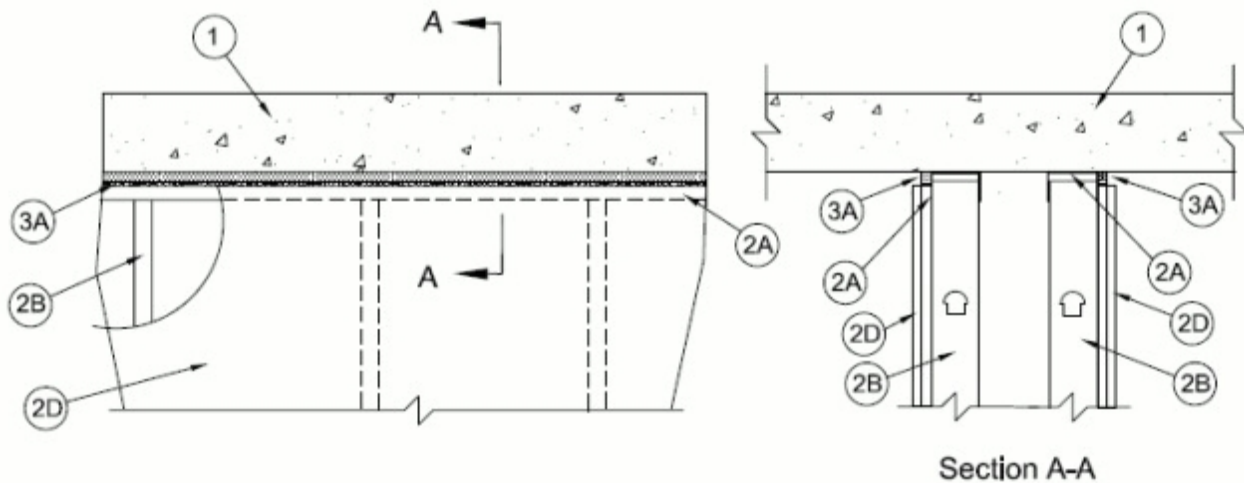

**1. Floor or Roof Assembly** — Min 4-1/2 in. (114 mm) thick reinforced lightweight or normal weight (100-150 pcf or 1600-2400 kg/m<sup>3</sup>) structural concrete.

**2. Chase Wall Assembly** — The 1 or 2 hr fire rated gypsum board/stud chase (double stud) wall assembly shall be constructed of the materials and in the manner described in the individual U400, V400 or W400 Series Wall and Partition Design in the UL Fire Resistance Directory and shall include the following construction features:

**A. Steel Floor and Ceiling Runners** — Channel shaped ceiling runner with width to accommodate studs, legs of min 2-1/2 in. (64 mm), and fabricated from min 20 MSG galv steel. Floor runners of wall assembly shall consist of min No. 25 ga galv steel channels sized to accommodate the steel studs. Floor runner to be provided with min 1-1/4 in. (32mm) flanges. Ceiling runner to be attached to concrete floor with steel masonry fasteners spaced a max of 24 in. (610 mm) O.C.

**A1. Light Gauge Framing\*** — Slotted Ceiling Runner - As an alternative to the ceiling runner in Item 2A, slotted ceiling runner to consist of galv steel channel with slotted flanges sized to accommodate steel studs (Item 2B). Slotted ceiling runner to be provided with minimum 2-1/2 in. (64 mm) flanges. Slotted ceiling runner secured to floor with steel concrete anchors spaced max 12 in. (305 mm) OC.

See **Light Gauge Framing** (XHLI) Category for names of Classified Companies.

**B. Studs** — Steel studs to be min 2-1/2 in. (64 mm) wide and formed of min 25 ga galv steel. Studs cut 3/4 to 1 in. (19 to 25 mm) less in length than assembly height with bottom nesting in

and secured to floor runner. Steel studs nested in ceiling runner without attachment. Studs spaced max 24 in. (610 mm) OC.

**C. Batts and Blankets\* (Not Shown)** — Faced or unfaced glass fiber insulation or mineral wool insulation completely filling stud cavity. Insulation shall meet the specifications described in the individual Wall and Partition Design.

See **Batts and Blankets** (BZJZ) Category for names of Classified Companies.

**D. Gypsum Board\*** — Gypsum board 5/8 in. (16 mm) thick, applied on both sides of wall as specified in the individual Wall and Partition Design except that a max 1/2 in. (13 mm) gap shall be maintained between the top of the gypsum board and the bottom of the floor assembly. The screws attaching the gypsum board to the studs along the top of the wall shall be located 3 to 3-1/2 in. (76 to 89 mm) down from floor at time of installation. No gypsum board attachment screws shall be driven into the ceiling runner.

**The hourly assembly rating and F, FT, FH and FTH ratings of the joint system is equal to the hourly fire rating of the wall.**

**3. Joint System — Max separation between bottom of floor and top of gypsum board (at time of installation) is 1/2 in. (13 mm). The joint system is designed to accommodate a max 50 percent compression or 25% extension from its installed width.** The joint system shall consist of the following:

**A. Fill, Void or Cavity Material\*** — Blaze Foam consists of nom 1-1/2 in. (38 mm) high by 5/8 in. (16 mm) thick foam with integral 1.5 mm by 5/8 in. (16 mm) wide intumescent strip adhered to bottom surface. One strip of Blaze Foam to be compressed and inserted into joint against the ceiling runner, between bottom of floor and top edge of gypsum board, with the intumescent strip positioned at bottom and resting on the cut edge of the gypsum board. Blaze Foam is supplied in varying lengths and shall be cut to length and friction fit within the joint with ends tightly butted. Butt joints in the Blaze Foam shall be spaced min 40 in. (102 mm) apart. Blaze Foam applied within joint opening on both finished sides of wall.

**RECTORSEAL** — Blaze Foam

**\* Indicates such products shall bear the UL or cUL Certification Mark for jurisdictions employing the UL or cUL Certification (such as Canada), respectively.**