



### System No. HW-D-0443

March 29, 2006

Assembly Ratings — 1 and 2 Hr (See Item 2)

Joint Width — 2 In. Maximum

Class II Movement Capabilities — 33 Percent Compression Only

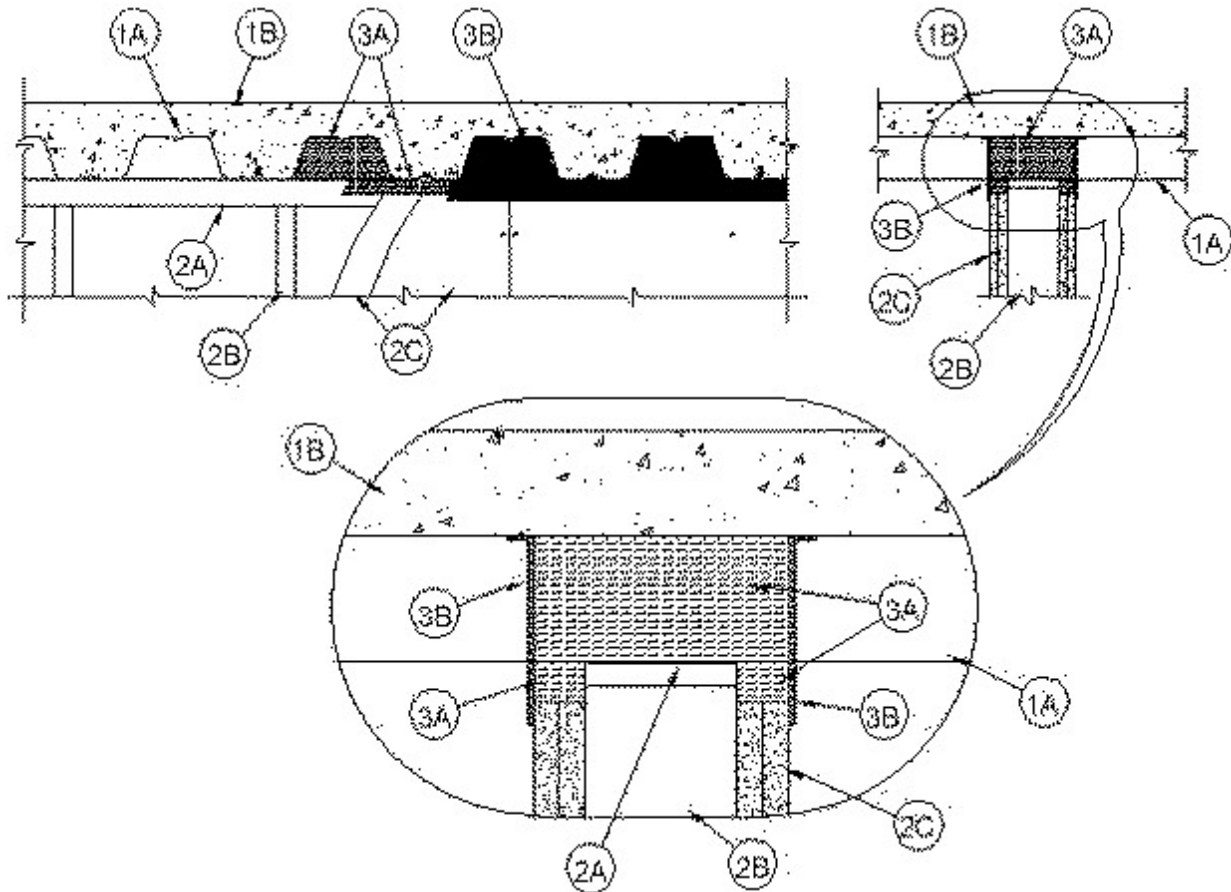

**1. Floor Assembly** — The fire-rated fluted steel deck/concrete floor assembly shall be constructed of the materials and in the manner described in the individual D900 Series Floor-Ceiling Design in the UL Fire Resistance Directory and shall include the following construction features:

- A. **Steel Floor And Form Units\*** — Max 3 in. (76 mm) deep galv steel fluted units.
- B. **Concrete** — Min 2-1/2 in. (64 mm) thick reinforced concrete, as measured from the top plane of the floor units.

**2. Wall Assembly** — The 1 or 2 hr fire rated gypsum board/steel stud wall assembly shall be constructed of the materials and in the manner described in the individual U400 or V400 Series Wall and Partition Design in the UL Fire Resistance Directory and shall include the following construction features:

- A. **Steel Floor And Ceiling Runners** — Floor and ceiling runners of wall assembly shall consist of galv steel channels sized to accommodate steel studs (Item 2B). Ceiling runner to be provided with min 2-1/2 in. (64 mm) flanges. Ceiling runner installed perpendicular to direction of fluted steel deck and secured to valleys with welds or steel masonry anchors spaced max 12 in. (305 mm) OC.
- B. **Studs** — Steel studs to be min 3-1/2 in. (89 mm) wide. Studs cut 1 to 1-1/2 in. (25 to 38 mm) less in length than assembly height with bottom nesting in and resting on floor runner and with

top nesting in ceiling runner without attachment. Stud spacing not to exceed 24 in. (610 mm) OC.

**C. Gypsum Board\*** — Gypsum board sheets installed to a min total thickness of 5/8 in. (16 mm) or 1-1/4 in. (32 mm) on each side of wall for 1 or 2 hr fire rated assemblies, respectively. Wall to be constructed as specified in the individual Wall and Partition Design in the UL Fire Resistance Directory, except that a nom 2 in. (51 mm) gap shall be maintained between the top of the gypsum board and the bottom of the steel floor units and the top row of screws shall be installed into the studs 1 to 1-1/2 in. (25 to 38 mm) below the bottom edge of the ceiling runner flange.

**The hourly assembly rating of the joint system is equal to the hourly fire rating of the wall.**

**3. Joint System** — Max separation between bottom of floor and top of wall at time of installation of joint system is 2 in. (51 mm). The joint system is designed to accommodate a max 33 percent compression from its installed width. The joint system consists of forming material and a fill material, as follows:

**A. Forming Material\*** — Min 8 pcf (128 kg/m<sup>3</sup>) density mineral wool batt insulation cut approx 25 percent wider and higher than the flutes and with a length equal to the overall thickness of the wall. Pieces tightly friction-fitted into the flutes of the steel floor units above the top of the ceiling runner. The mineral wool batt insulation is to project beyond each side of the ceiling runner, flush with wall surfaces. Nom 5/8 in. (16 mm) or 1-1/4 in. (32 mm) wide by min 2 in. (51 mm) high strips of min 8 pcf (128 kg/m<sup>3</sup>) mineral wool batt insulation are to be cut to fill the 2 in. gap between the top of the gypsum board and the bottom of the steel floor units. The strips of mineral wool are to be tightly friction-fitted, cut edge first, into the gap between the top of the gypsum board and the bottom of the steel floor units and the bottom of the mineral wool batt insulation in the flutes of the steel deck on both sides of the wall.

**ROCK WOOL MANUFACTURING CO** — Delta-8A

**B. Fill, Void or Cavity Material\*** — Min 1/8 in. (3.2 mm) wet thickness (min 1/16 in. or 1.6 mm dry thickness) of fill material sprayed or troweled on each side of the wall to completely cover mineral wool forming material and to overlap a min of 1/2 in. (13 mm) onto gypsum board and steel deck on both sides of wall.

**RECTORSEAL** — Metacaulk 1200 Spray, Metacaulk 1200 Caulk Grade

\*Bearing the UL Classification Mark