

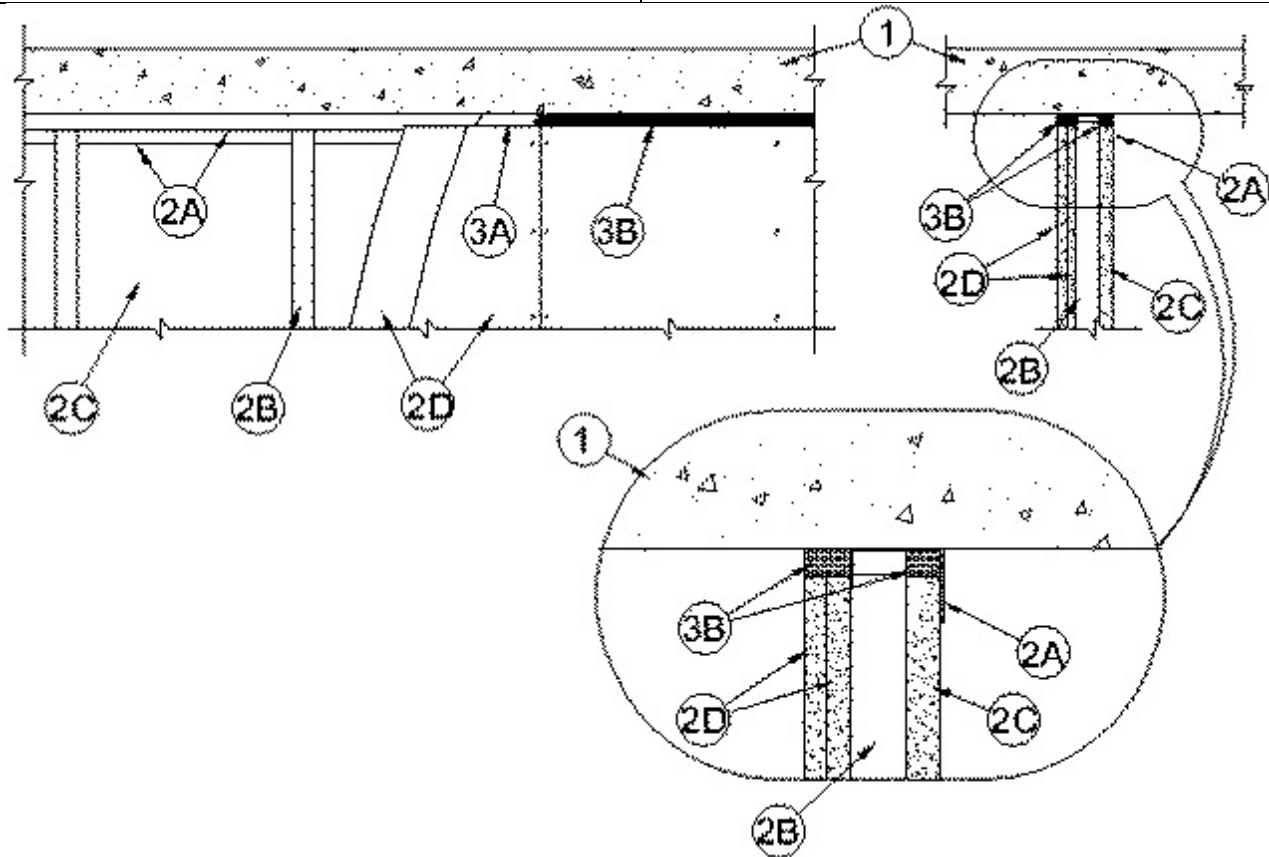

System No. HW-D-0401

July 10, 2014

ANSI/UL2079	CAN/ULC S115
Assembly Rating — 1 and 2 Hr (See Item 2)	F Rating — 1 and 2 Hr (See Item 2)
Nominal Joint Width - 1 In.	FT Rating — 1 and 2 Hr (See Item 2)
Class II or III Movement Capabilities — 25% Compression or Extension	FH Rating — 1 and 2 Hr (See Item 2)
	FTH Rating — 1 and 2 Hr (See Item 2)
	Nominal Joint Width - 25 mm
	Class II or III Movement Capabilities — 25 % Compression or Extension



1. Floor Assembly — Min 2-1/2 in. (64 mm) thick reinforced lightweight or normal weight (100-150 pcf or 1600-2400 kg/m³) structural concrete.

2. Shaft Wall Assembly — The 1 or 2 hr fire rated shaft wall assembly shall be constructed of the materials and in the manner described in the individual U400 or V400 Series Wall and Partition Design in the UL Fire Resistance Directory. The wall shall include the following construction features:

A. Floor and Ceiling Runners — "J"-shaped runner, min 2-1/2 in. (64 mm) wide with unequal legs of min 1 in. (25 mm) and min 2 in. (51 mm), fabricated from min 24 MSG galv steel. The length of the shorter leg of the "J"-shaped runner used for the ceiling runner shall be min 1/4 in. (6 mm) greater than the joint width. Runners positioned with shorter leg toward finished side of wall. Runners attached to floor and ceiling with steel fasteners spaced max 24 in. (610 mm) OC. As an alternate to the "J"-shaped runner, a min 2-1/2 in. (64 mm) wide by 1 or 1-1/4 in. (25 or 32 mm) deep channel formed from min 24 MSG galv steel may be used for the floor runner.

A1. **Light Gauge Framing* — Slotted Ceiling Track** — (Not Shown) - As an alternate to the "J"-shaped runner in Item 2A, a ceiling track consisting of galv steel channel with slotted flanges may be used. Slotted ceiling track sized to accommodate steel "C-T", "I" or "C-H" studs (Item 2C). Attached to concrete at ceiling with steel fasteners spaced max 24 in. (610 mm) OC.

BRADY CONSTRUCTION INNOVATIONS INC, DBA SLIPTRACK SYSTEMS — SLP-TRK

A2. **Light Gauge Framing Members*** — (Not Shown) - As an option, the steel studs (Item 3B) may incorporate vertical deflection clips for attachment to the ceiling runner (Item 3A) in accordance with the manufacturer's instructions.

THE STEEL NETWORK INC — VertiClip SLD 250, VertiClip SLD 400

B. **Steel Studs** — "C-T", "I" or "C-H"-shaped steel studs to be min 2-1/2 in. (64 mm) wide and formed of min 24 MSG galv steel. Studs cut 1/2 to 3/4 in. (13 to 19 mm) less in length than assembly height with bottom nesting in and resting on floor runner and with top nesting in "J"-shaped runner or slotted ceiling track. Studs spaced max 24 in. (610 mm) OC. After installation of gypsum board liner panels (Item 2D), studs secured to flange of floor runner on finished side of wall only with No. 6 by 1/2 in. (13 mm) long self-drilling, self-tapping steel screws. If slotted ceiling track (Item 2A1) is used, studs secured to flange of slotted ceiling track on finished side of wall only with No. 8 by 1/2 in. (13 mm) long self-drilling, self-tapping wafer head steel screws at slot midheight.

C. **Gypsum Board*** — 1 in. (25 mm) thick by max 24 in. (610 mm) wide gypsum board liner panels. Panels cut max 1 in. (25 mm) less in length than floor to ceiling height. Vertical edges inserted into "T"-shaped section of "C-T" studs, into holding tabs of "I" studs or into "H"-shaped section of "C-H" studs.

D. **Gypsum Board*** — Gypsum board sheets, 1/2 or 5/8 in. (13 or 16 mm) thick, applied on finished side of wall as specified in the individual Wall and Partition Design. A max 1 in. (25 mm) gap shall be maintained between the top of the gypsum board and the bottom surface of the concrete floor. The screws attaching the gypsum board layer(s) to the "C-T", "I" or "C-H" studs shall be located 1 in. (25 mm) below the bottom of the "J"-shaped runner (Item 2A) or slotted ceiling track (Item 2A1). No gypsum board attachment screws are to penetrate the ceiling runner.

3. Joint System — Max separation between bottom of floor and top of liner panel (Item 2C) and between bottom of floor and top of gypsum board (Item 2D) at time of installation of joint system is 1 in. (25 mm). The joint system is designed to accommodate a maximum 25 percent compression from its installed width. The joint system consists of bond breaker tape and sealant, as follows:

A. **Bond Breaker Tape** — Polyethylene tape supplied in rolls. Tape applied to flanges of "J"-shaped runner (Item 2A) or slotted ceiling track (Item 2A1) to prevent bonding of the sealant at points other than the top and bottom of the linear gap. When FS 900+ is used, bond breaker tape is not required.

B. **Fill, Void or Cavity Material* — Sealant** — Min 1 in. (25 mm) depth of sealant to be installed to fill linear gap between top of gypsum board liner panel (Item 2C) and top inside surface of "J"-shaped ceiling runner or slotted ceiling track prior to installation of gypsum board sheets on finished side of wall. The depth of sealant to be installed to fill the linear gap between the top of the gypsum board sheets (Item 2D) and the bottom of the concrete floor shall be equal to the overall thickness of the gypsum board sheets and shall be flush with the finished side of the wall.

RECTORSEAL — FlameSafe FS900+, FS1900, Metacaulk 1000, Metacaulk 350i, Metacaulk 1200, Biostop 350i, Biostop 500+ or Biostop 750

* Indicates such products shall bear the UL or cUL Certification Mark for jurisdictions employing the UL or cUL Certification (such as Canada), respectively.