

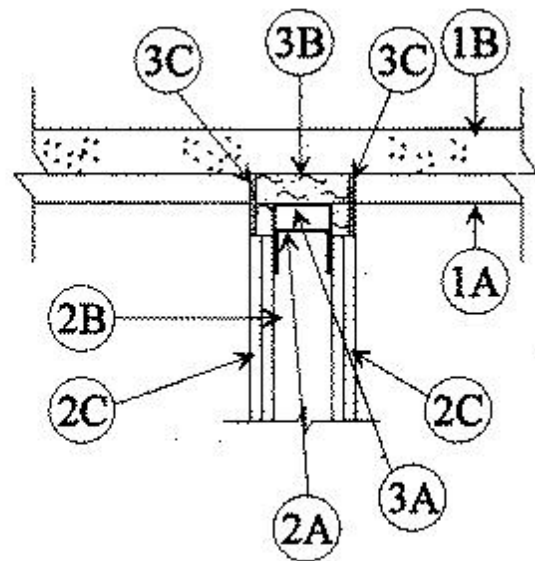

**System No. HW-D-0146**

July 15, 2014

ANSI/UL2079	CAN/ULC S115
Assembly Rating — 1 and 2 Hr (See Item 2)	F Rating — 1 and 2 Hr (See Item 2)
Nominal Joint Width - 1 In.	FT Rating — 1 and 2 Hr(See Item 2)
Class II Movement Capabilities -25% Compression	FH Rating — 1 and 2 Hr (See Item 2)
	FTH Rating — 1 and 2 Hr (See Item 2)
	Nominal Joint Width - 1 In.
	Class II Movement Capabilities -25% Compression

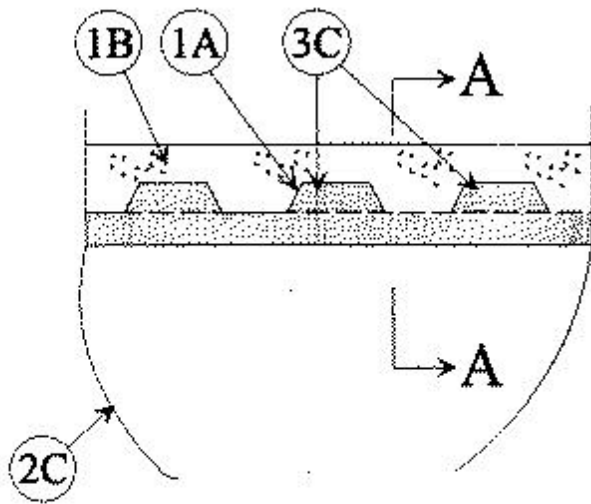

**SECTION A-A**

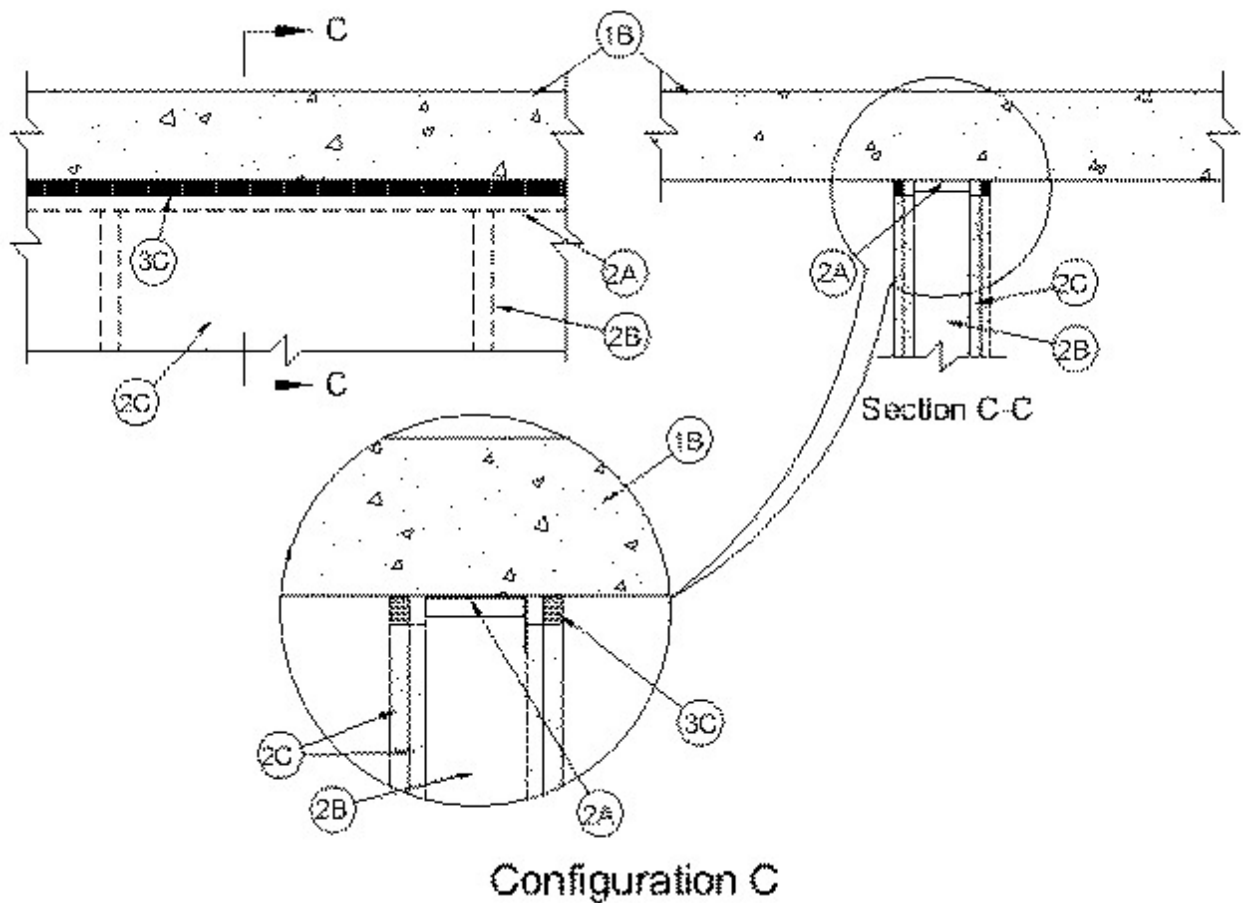
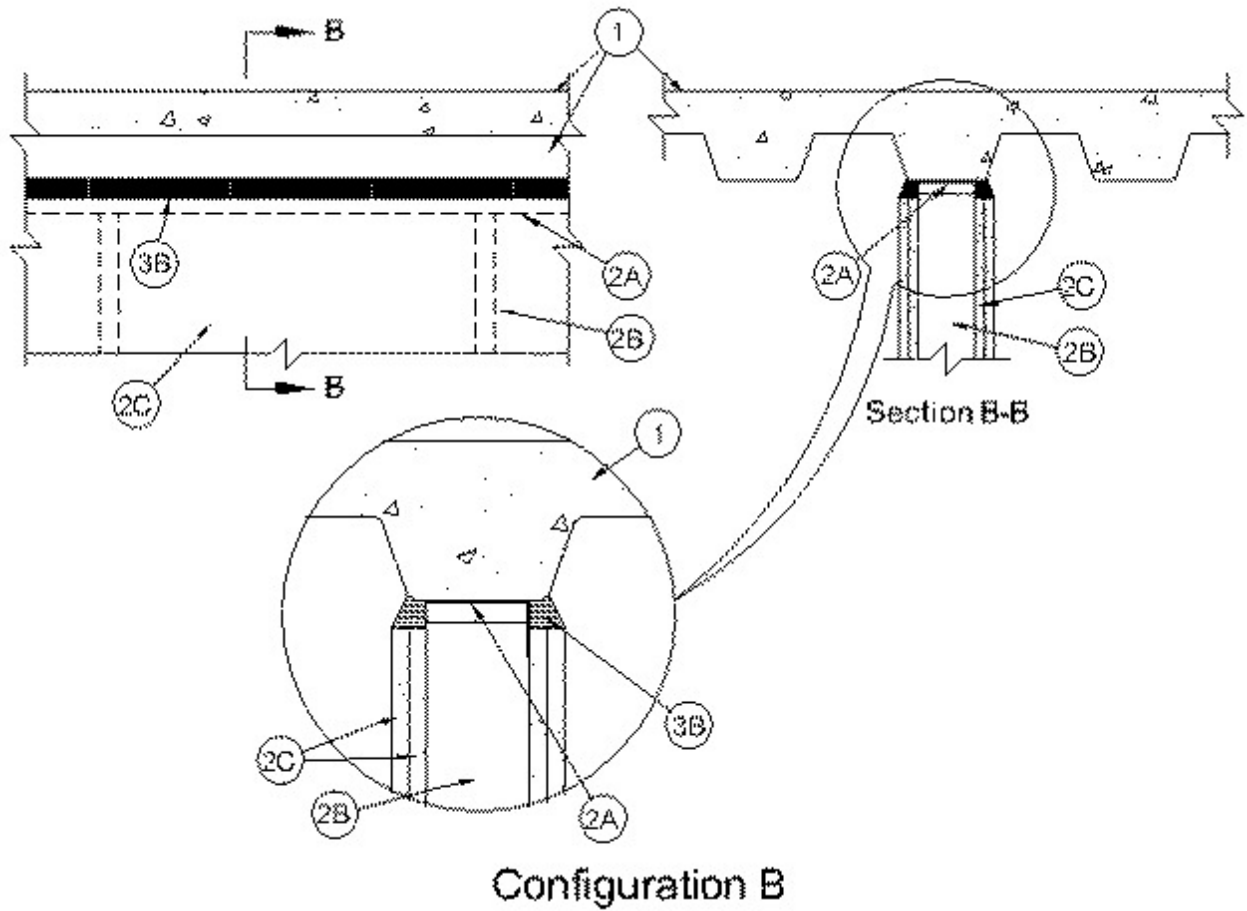

**1. Floor Assembly** — The fire-rated fluted steel deck/concrete floor assembly shall be constructed of the materials and in the manner described in the individual Floor-Ceiling Design in the UL Fire Resistance Directory and shall include the following construction features:

**A. Steel Floor And Form Units\*** — Max 3 in. (76 mm) deep galv steel fluted floor units.

**B. Concrete** — Min 3 in. (76 mm) thick reinforced lightweight or normal weight (100-150 pcf or 1600-2400 kg/m<sup>3</sup>) concrete, as measured from the top plane of the floor units.

**1A. Roof Assembly** — (Not Shown) — As an alternate to the floor assembly, a fire-rated fluted steel deck roof assembly may be used. The roof assembly shall be constructed of the materials and in the manner described in the individual P900 Series Roof-Ceiling Design in the UL Fire Resistance Directory. The hourly rating of the roof assembly shall be equal to or greater than the hourly rating of the wall assembly. The roof assembly shall include the following construction features:

**A. Steel Roof Deck Max** — Max 3 in. (76 mm) deep galv steel fluted roof deck.

**B. Roof Insulation** — Min 2-1/4 in. (57 mm) thick poured insulating concrete, as measured from the top plane of the roof deck.

**C. Roof Covering** — Hot-mopped or cold application materials compatible with concrete.

**1B. Floor Assembly** — As an alternate to the floor and roof assemblies (Items 1 and 1A), the floor may consist of a min 4-1/2 in. (114 mm) thick reinforced lightweight or normal weight (100-150 pcf or 1600-2400 kg/m<sup>3</sup>) concrete slab.

**2. Wall Assembly** — The 1 or 2 hr fire-rated gypsum board/steel stud wall assembly shall be constructed of the materials and in the manner described in the individual U400 or V400 Series Wall and Partition Design in the UL Fire Resistance Directory and shall include the following construction features:

**A. Steel Floor And Ceiling Runners** — Floor and ceiling runners of wall assembly shall consist of galv steel channels sized to accommodate steel studs (Item 2B). Ceiling runner to be provided with min 1-1/4 in. (32 mm) flanges. Studs and gypsum board must have a min 1/4 in. (6 mm) engagement onto the flanges of the ceiling runner at the furthest point of extension of the joint. Ceiling runner installed perpendicular to steel deck (Configuration A) or centered on valleys of steel deck (Configuration B). When U shaped deflection channel (Item 3A) is used, ceiling runner is installed within the U-shaped deflection channel with 1 in. (25 mm) gap maintained between the top of ceiling runner and top of deflection channel. When deflection channel is not used, ceiling runner secured to valleys with steel masonry anchors or by welds spaced max 24 in. (610 mm) OC. When concrete slab floor assembly (Item 1B) is used and deflection channel is not used, ceiling runner secured to concrete floor slab (Configuration C) with steel masonry anchors spaced max 24 in. (610 mm) OC.

**A1. Light Gauge Framing\* - Slotted Ceiling Runner** — Slotted ceiling runner may be used as an alternate to the ceiling runner in Item 2A. Slotted ceiling runner to consist of galv steel channel with slotted flanges sized to accommodate steel studs (Item 2B). Slotted ceiling runner secured to valleys of steel deck with steel masonry anchors spaced max 24 in. (610 mm) OC. When concrete slab floor assembly (Item 1B) is used, slotted ceiling runner secured to concrete floor slab with steel masonry anchors spaced max 24 in. (610 mm) OC. When slotted ceiling runner is used, deflection channel (Item 3A) shall not be used.

**SCAFCO STEEL STUD MANUFACTURING CO**

**BRADY CONSTRUCTION INNOVATIONS INC, DBA SLIPTRACK SYSTEMS** — SLP-TRK

**MARINO/WARE, DIV OF WARE INDUSTRIES INC** — Type SLT

**TELLING INDUSTRIES L L C** — True-Action Deflection Track

**A2. Light Gauge Framing\* — Vertical Deflection Clip\*** — (Optional) Steel clips can be used in conjunction with steel studs (Item 2B), ceiling runner (Item 2A) or deflection channel (Item 3A). Clips installed over the top of studs and inserted within the ceiling runner or deflection channel. Clip shall be secured to the ceiling runner or deflection channel with No. 8 self drilling, self tapping steel fasteners through holes provided within the clip. Clip may be secured to the stud with No. 6 pan head steel screw through holes provided within the clip. As an alternate, the legs of the clip may be installed over the top of the stud without attachment in accordance with manufacturer's installation instructions.

**FLEX-ABILITY CONCEPTS L L C** — Three Legged Dog Deflection Clip

**A3. Light Gauge Framing\*- Notched Ceiling Runner** — As an alternate to the ceiling runners in Items 2A through 2A3, notched ceiling runners to consist of C-shaped galv steel channel with notched return flanges sized to accommodate steel studs (Item 2B). Notched ceiling runner secured to valleys of steel deck with steel masonry anchors spaced max 24 in. OC. When concrete slab floor assembly (Item 1B) is used, slotted ceiling runner secured to concrete floor slab with steel masonry anchors spaced max 24 in. (610 mm) OC. When notched ceiling runner is used, deflection channel (Item 3A) shall not be used.

**OLMAR SUPPLY INC** — Type SCR

**B. Studs** — Steel studs to be min 3-5/8 1/2 in. (89 mm) wide. Studs cut 3/4 in. (19 mm) less in length than assembly height with bottom nesting in and secured to floor runner. Studs and gypsum board must have a min 1/4 in. (6 mm) engagement onto the flanges of the ceiling runner at the furthest point of extension of the joint. When deflection channel (Item 3A) is used, steel studs attached to ceiling runner (Item 2A) with sheet metal screws located 1/2 in. (13 mm) below bottom of deflection channel. When deflection channel is not used, steel studs shall not be secured to ceiling runner. Stud spacing not to exceed 24 in. (610 mm) OC.

**C. Gypsum Board\*** — Gypsum board sheets installed to min total thickness of 5/8 in. (16 mm) and 1-1/4 in. (32 mm) on each side of wall for 1 and 2 hr fire-rated assemblies, respectively. Wall to be constructed as specified in the individual Wall and Partition Design in the UL Fire Resistance Directory, except that a nom 1 in. (25 mm) gap shall be maintained between the top of the gypsum board and the lower surface of the floor or roof deck. The screws attaching the gypsum board to studs at the top of the wall shall be located 1 in. (25 mm) below the bottom of the edge of the ceiling runner.

**The hourly fire rating of the joint system is equal to the hourly fire rating of the wall.**

**3. Joint System — Max separation between bottom of steel deck or concrete floor and top of wall (at time of installation of joint system) is 1 in. The joint system is designed to accommodate a max 25 percent compression from its' installed width.** The joint system shall consist of forming and fill materials, with or without a deflection channel (Item 3A), as follows:

#### **Joint Configuration A**

**A. Deflection Channel** — (Optional, Not Shown) — Nom 3 in. (76 mm) deep by min 25 gauge galv steel channel sized to accommodate ceiling runner (Item 2A). Deflection channel installed perpendicular to direction of fluted steel deck and secured to valleys of steel deck with steel masonry anchors or welds spaced max 24 in. (610 mm) OC. When concrete slab floor assembly (Item 1B) is used, deflection channel secured to concrete floor slab with steel masonry anchors spaced max 24 in. (610 mm) OC. The ceiling runner (Item 2A) is installed within the deflection channel to maintain a 1 in. (25 mm) gap between the top of the ceiling runner and the top of the deflection channel. The ceiling runner nests inside the deflection channel without attachment.

**B. Forming Material\*** — Min 3-1/2 in. (89 mm) or 4-7/8 in. (124 mm) depth of 4 pcf (64 kg/m<sup>3</sup>) mineral wool batt insulation, for 1 and 2 hr rated wall assemblies, respectively, cut to the shape of the fluted deck, approx 20 percent larger than the area of the flutes and compressed into the flutes of the steel floor unit or roof deck flutes above the ceiling channel. For 2 hr assembly, an additional 2 in. (51 mm) thick by 1 in. (25 mm) wide sections of mineral wool batt insulation compressed 50 percent in thickness and installed cut edge first to fill the 1 in. (25 mm) gap between the top of gypsum board and bottom of the steel floor units or roof deck. The forming material shall be recessed 5/8 in. (16 mm) from each side of the wall.

**IIG MINWOOL L L C** — MinWool-1200 Safing

**ROCK WOOL MANUFACTURING CO** — Delta Safing Insulation

**ROCKWOOL MALAYSIA SDN BHD** — SAFE Mineral Wool

**ROXUL INC** — SAFE Mineral Wool

**B1. Forming Material\* - Plugs** — (Optional-Not Shown) As an alternate to the forming material (Item 3A), mineral wool plugs preformed to the shape of the fluted floor units or roof deck, may be used within the flutes. Plugs shall be friction fitted to completely fill the flutes above the ceiling channel. In the 2 hr fire rated wall assemblies, the plugs shall project beyond each side of the ceiling runner and recessed from each surface of wall to accommodate the required thickness of fill material. In the 1 hr fire rated wall assemblies, the plugs shall be flush with ceiling runner and recessed from each surface of wall to accommodate the required thickness of fill material. Additional forming material, described in Item 3A, to be used in conjunction with the plugs to fill the gap between the top of gypsum board and bottom of steel floor units or roof deck.

**ROCK WOOL MANUFACTURING CO** — Deck Plugs

**C. Fill, Void or Cavity Material\* — Sealant** — Min 5/8 in. thickness of fill material installed on each side of the wall in the flutes of the steel floor or roof deck and between the top of the wall and the bottom of the steel floor or roof deck flush with each surface of wall.

**RECTORSEAL** — FS 900+ Elastomeric Sealant, Metacaulk MC 150+, or Biostop BF 150+.

### Joint Configuration B

**A. Deflection Channel** — Optional, Not Shown - Nom 3 in. (76 mm) deep by min 25 ga steel U-shaped channel centered on valleys of steel floor units or roof deck. Deflection channel secured with steel fasteners or by welds spaced max 24 in. (610 mm) OC. Deflection channel installed perpendicular to direction of fluted steel deck and secured to valleys with steel fasteners spaced max 24 in. (610 mm) OC. When floor assembly (Item 1B) is used, deflection channel secured to concrete floor slab with steel fasteners spaced max 24 in. (610 mm) OC. The ceiling runner (Item 2A) is installed within the deflection channel to maintain a 1 in. (25 mm) gap between the top of the ceiling runner and the top of the deflection channel. The ceiling runner is not fastened to the deflection channel.

**B. Fill, Void or Cavity Material\* - Sealant** — Min 5/8 in. (16 mm) thickness of fill material installed on each side of the wall between the top of the wall and bottom of floor unit or roof deck, flush with both sides of the wall.

**RECTORSEAL** — FS 900+ Elastomeric Sealant, Metacaulk MC 150+, or Biostop BF 150+.

### Joint Configuration C

**A. Deflection Channel** — (Optional, Not Shown) — Nom 3 in. (76 mm) deep by min 25 gauge steel U-shaped channel. Deflection channel secured to concrete floor with steel fasteners spaced max 24 in. (610 mm) OC. Deflection channel secured to concrete floor with steel fasteners spaced max 24 in. (610 mm) OC. The ceiling runner is installed within the deflection channel to maintain a 1 in. (25 mm) gap between the top of the ceiling runner and the top of the deflection channel. The ceiling runner is not fastened to the deflection channel.

**B. Packing Material** — For optional use in 2 hr fire rated assemblies. Foam backer rod friction fitted into joint opening and recessed to accommodate the required thickness of fill material.

**C. Fill, Void or Cavity Material\* - Sealant** — Min 5/8 in. (16 mm) thickness of fill material installed on each side of the wall between the top of the wall and bottom of floor, flush with each surface of wall. The use of bond breaker tape is dependent upon the type of fill material used within the joint system. If 900+ Sealant is used within the joint system, bond breaker tape is not required. If 1900 Sealant is used within the joint system, bond breaker tape shall be applied to the ceiling runner (Item 2A) or deflection channel (Item 3A) prior to the installation of fill material on both sides of the wall in 1 hr fire rated wall assemblies and in 2 hr fire rated wall assemblies where optional backer rod is not used.

**RECTORSEAL** — FS 900+ Elastomeric Sealant, FS 1900 Sealant, Metacaulk MC 150+, or Biostop BF 150+.

\* Indicates such products shall bear the UL or cUL Certification Mark for jurisdictions employing the UL or cUL Certification (such as Canada), respectively.