

System No. C-AJ-7030

December 05, 2007

F Rating — 2 Hr

T Rating — 2 Hr

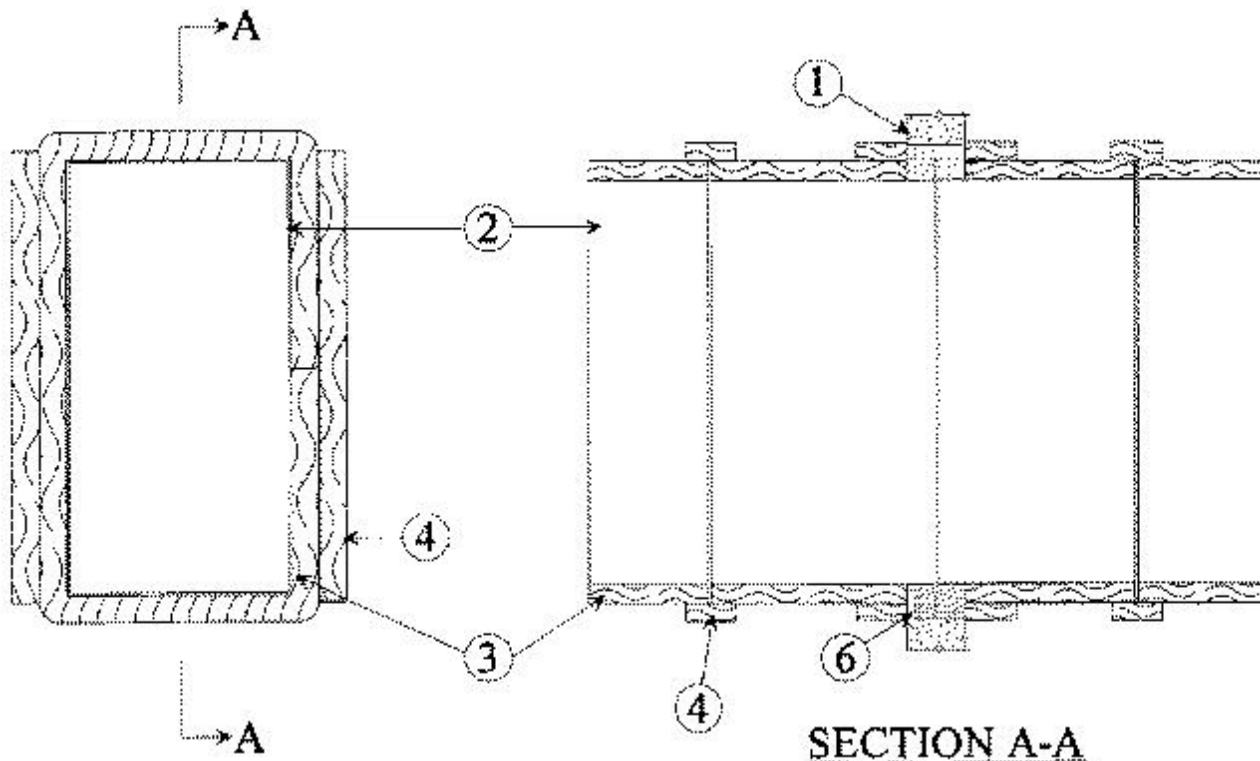

1. **Floor or Wall Assembly** — Min 4-1/2 in. (114 mm) thick reinforced lightweight or normal weight (100-150 pcf or 1600-2400 kg/m³) concrete. Wall may also be constructed of any UL Classified **Concrete Blocks***. For rectangular ducts, max area of opening shall be 1936 in². with max dimension of 44 in. (1118 mm). For round ducts, max diam of opening shall be 44 in. (1118 mm). For oval shaped ducts, max dimension of opening shall be 44 in. (1118 mm) by 14 in. (356 mm).

See **Concrete Blocks** (CAZT) category in the Fire Resistance Directory for names of manufacturers.

2. **Through-Penetrants — Coated Ducts*** — Rectangular, round or flat oval coated steel air duct. For rectangular ducts, max perimeter dimension shall be 160 in. (4064 mm) and a max individual dimension shall be 40 in. (1016 mm). For round ducts, max diam shall be 40 in. (1016 mm) and for oval shaped ducts, max size of oval shall be 40 in. (1016 mm) by 10 in. (254 mm). Duct supplied coated with BW11 coating material. One duct to be centered within the firestop system with an annular space of 2 in. (51 mm). Reinforcement stiffener or transverse joint with bolted flanges shall be located approximately at the mid depth of the annular space. Duct to be rigidly supported on both sides of the floor or wall assembly. Duct sections shall be assembled using bolted flanges or SMACNA approved Transverse Joint Reinforcements.

FIRESPRAY INTERNATIONAL LTD — FLAMEBAR BW11 FIRE RATED DUCTWORK

3. **Batts and Blankets*** — Nom 2 in. (51 mm) thick unfaced mineral wool batts having a min density of 6 pcf (96 kg/m³). Single layer of mineral wool batt material installed on duct with all joints sealed with a 4 in. (102 mm) wide pressure sensitive aluminum foil tape at each transverse joint, insulation material shall be cut to provide an overlapping (strip lapped) joint of 1 in. (25 mm).

See **Batts and Blankets** (BZJZ) category in the **Fire Resistance Directory** or **Batts and Blankets*** (BKNV) category in the **Building Materials Directory** for names of manufacturers.

4. **Insulation Collar** — Fabricated from the same mineral wool insulation material described in Item 3. Strips are 8 in. (203 mm) wide and are centered over each joint between adjacent ventilation duct sections, over each ventilation duct stiffener, and adjacent to each Firestop System.

5. **Steel Banding Straps** — (Not Shown) — Min 3/4 in. (19 mm) wide by 0.015 in. (0.38 mm) thick stainless steel banding strips used in conjunction with min 3/4 in. (19 mm) wide by 1 in. (25 mm) long stainless steel crimp clips. Banding strips spaced a max of 12 in. (305 mm) OC. Two banding strips used to secure each insulation collar (Item 4).

6. **Firestop System** — The firestop system shall consist of the following:

A. **Forms** — (Not Shown) — Used as a form to prevent leakage of fill material during installation. Forms to be a rigid sheet material, cut to fit the contour of the penetrating item and fastened to the underside of the floor or both sides of wall. Forms to be removed after fill material has cured.

B. **Fill, Void or Cavity Material* — Mortar** — Fill material applied within the annulus, flush with top and bottom surfaces of floor or with both surfaces of wall. Mortar is mixed with water by volume in accordance with the mortar manufacturer's installation instructions.

A/D FIRE PROTECTION SYSTEMS INC — A/D Firebarrier Mortar

COGNIS DEUTSCHLAND GMBH & CO KG — KBS Mortar Seal

HILTI CONSTRUCTION CHEMICALS, DIV OF

HILTI INC — CP637 Mortar

ISOLATEK INTERNATIONAL — Cafco TPS Mortar

EGS NELSON FIRESTOP — CMP Mortar

RECTORSEAL — Bio K10+ Mortar

SANDERSFIRE INTERNATIONAL LTD — Firecrete Mortar

SPECIFIED TECHNOLOGIES INC — SpecSeal Mortar

FPT FLAMMADUR, DIV OF FIRE PROTECTION

TECHNOLOGIES INC — E473 Mortar.

TREMCO INC — TREMstop M mortar

W R GRACE & CO - CONN — KBS Mortar

3M COMPANY — Fire Barrier Motar