

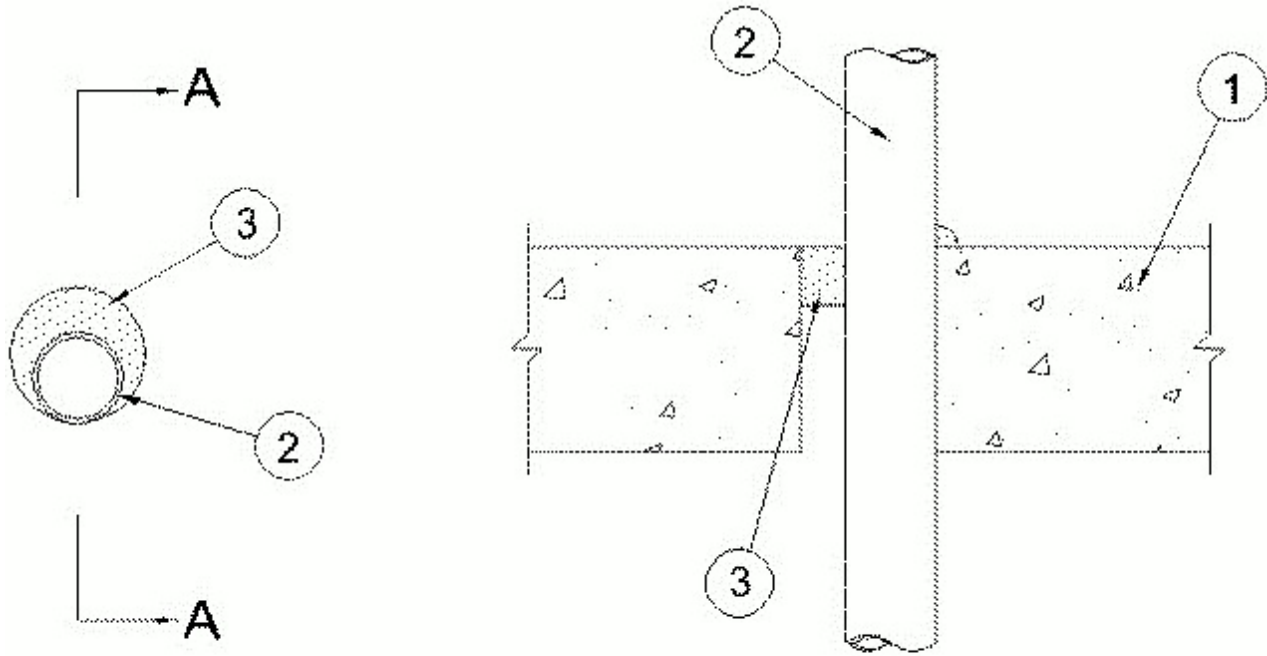

System No. C-AJ-2688

May 19, 2014

ANSI/UL1479 (ASTM E814)	CAN/ULC S115
F Rating — 2 Hr	F Rating — 2 Hr
T Rating — 0 Hr	FT Rating — 0 Hr
	FH Rating — 2 Hr
	FTH Rating — 0 Hr



SECTION A-A

System tested with a pressure differential of 50 Pa between the exposed and the unexposed surfaces with the higher pressure on the exposed side.

1. **Floor or Wall Assembly** — Min 114 mm (4-1/2 in.) thick reinforced lightweight or normal weight (1600-2400 kg/cu meter or 100-150 pcf) concrete. Max diam of opening is 76 mm (3 in.).

1A. **Steel Deck/Floor Assembly** — (Not Shown) — As an alternate to Item 1, the floor assembly may consist of a fluted steel deck/concrete floor assembly. The floor assembly shall be constructed of the materials and in the manner described in the individual Floor-Ceiling Design in the UL Fire Resistance Directory and shall include the following construction features:

A. **Steel Floor and Form Units*** — Min 64 mm (2-1/2 in.) deep galv fluted units.

B. **Concrete** — Min 64 mm (2-1/2 in.) thick reinforced concrete, as measured from the top plane of the floor units.

2. **Through Penetrants** — One nonmetallic pipe or conduit installed eccentrically or concentrically within opening. Annular space between penetrant and periphery of opening to be min 0 mm (0 in., point contact) to max 16 mm (5/8 in.). Penetrant to be rigidly supported on both sides of floor or wall assembly. The following types and sizes of penetrants may be used:

A. **Polyvinyl Chloride (PVC) Pipe** — Nom 51 mm (2 in.) diam (or smaller) Schedule 40 solid core or cellular core PVC pipe for use in closed (process or supply) or vented (drain, waste or

vent) piping systems.

B. Chlorinated Polyvinyl Chloride (CPVC) Pipe — Nom 51 mm (2 in.) diam (or smaller) SDR13.5 CPVC pipe for use in closed (process or supply) piping systems.

C. Rigid Nonmetallic Conduit+ — Nom 51 mm (2 in.) diam (or smaller) Schedule 40 PVC conduit installed in accordance with the National Electrical Code (NFPA No. 70).

D. Acrylonitrile Butadiene Styrene (ABS) Pipe — Nom 51 mm (2 in.) diam (or smaller) Schedule 40 solid core or cellular core ABS pipe for use in closed (process or supply) or vented (drain, waste or vent) piping systems.

3. Fill, Void or Cavity Materials* — (Caulk) - Min 51 mm (2 in.) thickness of caulk applied within the annulus, flush with top surface of floor or both surfaces of wall. At point contact location, a min 13 mm (1/2 in.) diam bead of fill material shall be applied to the concrete/penetrant interface on top surface of floor or both surfaces of wall.

RECTORSEAL — Metacaulk 1000 or Metacaulk 350i

*** Indicates such products shall bear the UL or cUL Certification Mark for jurisdictions employing the UL or cUL Certification (such as Canada), respectively.**