

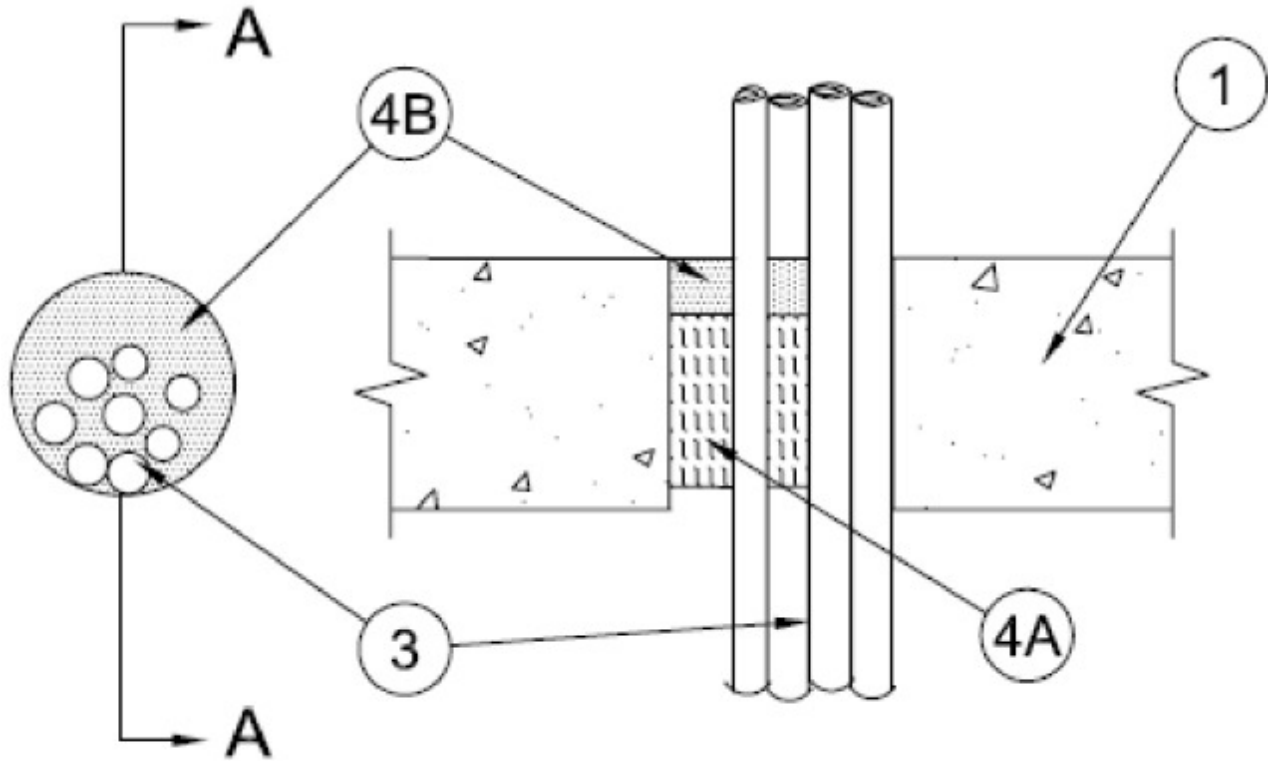

### System No. C-AJ-2622

July 16, 2014

ANSI/UL1479 (ASTM E814)	CAN/ULC S115
F Ratings - 3 Hr	F Ratings - 3 Hr
T Ratings - 2 and 3 Hr ( See Item 2)	FT Ratings - 2 and 3 Hr ( See Item 2)
	FH Ratings - 3 Hr
	FTH Ratings -2 and 3 Hr ( See Item 2)
L Rating At Ambient - Less Than 1 CFM/sq ft	L Rating At Ambient - Less Than 1 CFM/sq ft
L Rating At 400° F - Less Than 1 CFM/sq ft	L Rating At 400° F - Less Than 1 CFM/sq ft



## SECTION A-A

**1. Floor or Wall Assembly** — Min 4-1/2 in. (114 mm) thick lightweight or normal weight (100-150 pcf or 1600-2400 kg/m<sup>3</sup>) concrete floor or min 5 in. (127 mm) thick reinforced lightweight or normal weight concrete wall. Wall may also be constructed of any UL Classified **Concrete Blocks\***. Floor may also be constructed of any min 6 in. (152 mm) thick UL Classified hollow core **Precast Concrete Units\***. Max diam of opening is 4 in. (102 mm).

See **Concrete Blocks (CAZT)** and **Precast Concrete Units (CFTV)** categories in the Fire Resistance Directory for names of manufacturers.

**2. Steel Sleeve** — (Optional. Not Shown) - Nom 4 in. (102 mm) diam (or smaller) Schedule 10 (or heavier) steel pipe cast or grouted into floor or wall assembly, flush with floor or wall surfaces. **When steel sleeve is used, T Rating for firestop system is 2 hr.**

**3. Through-Penetrants** — One or more nonmetallic tubes to be loosely bundled together and installed eccentrically or concentrically within the firestop system. Aggregate cross-sectional area of penetrants not to exceed 25 percent of the cross-sectional area of the opening. The annular space between the tubes and the periphery of the opening shall be min 0 in. (point contact) to max 1 in. (25 mm). Separation between tubes to be min 0 in. (point contact) to max 1 in. (25 mm). Tubes to be rigidly supported on both sides of floor or wall assembly. The following types and sizes of nonmetallic tubes

may be used:

A. **Cross Linked Polyethylene (PEX) Tubing** — Nom 5/8 in. (16 mm) diam (or smaller) SDR 9 crosslinked polyethylene (PEX) tubing for use in closed (process or supply) piping systems.

4. **Firestop System** — The firestop system shall consist of the following:

A. **Packing Material** — Min 3 in. (76 mm) thickness of min 4 pcf (64 kg/m<sup>3</sup>) mineral wool batt insulation firmly packed into opening within annular space between and around penetrants as a permanent form. Packing material to be recessed from top surface of floor or both surfaces of wall to accommodate the required thickness of fill material (Item 4B). In precast hollow core concrete unit floors, packing material to be recessed from top and bottom surfaces of floor to accommodate the required thickness of fill material.

B. **Fill, Void or Cavity Material\* - Sealant** — Min 1 in. (25 mm) thickness of fill material applied within annulus between and around penetrants, flush with top surface of floor or both surfaces of wall. In precast hollow core concrete unit floors, fill material to be applied within annulus, flush with top and bottom surfaces of floor. Sealant to be forced into interstices of tubing group to max extent possible. A min 3/8 in. (10 mm) diam bead of fill material shall be applied at point contact locations between penetrants and concrete or steel sleeve at top surface of floor, or both surfaces of wall or precast concrete units.

**RECTORSEAL** — FS 900+ Sealant, Metacaulk MC 150+, Biostop BF 150+

\* Indicates such products shall bear the UL or cUL Certification Mark for jurisdictions employing the UL or cUL Certification (such as Canada), respectively.