



System No. C-AJ-2427

June 02, 2011

F Rating — 2 Hr

T Rating — 2 Hr

W Rating - Class 1 (See Item 3)

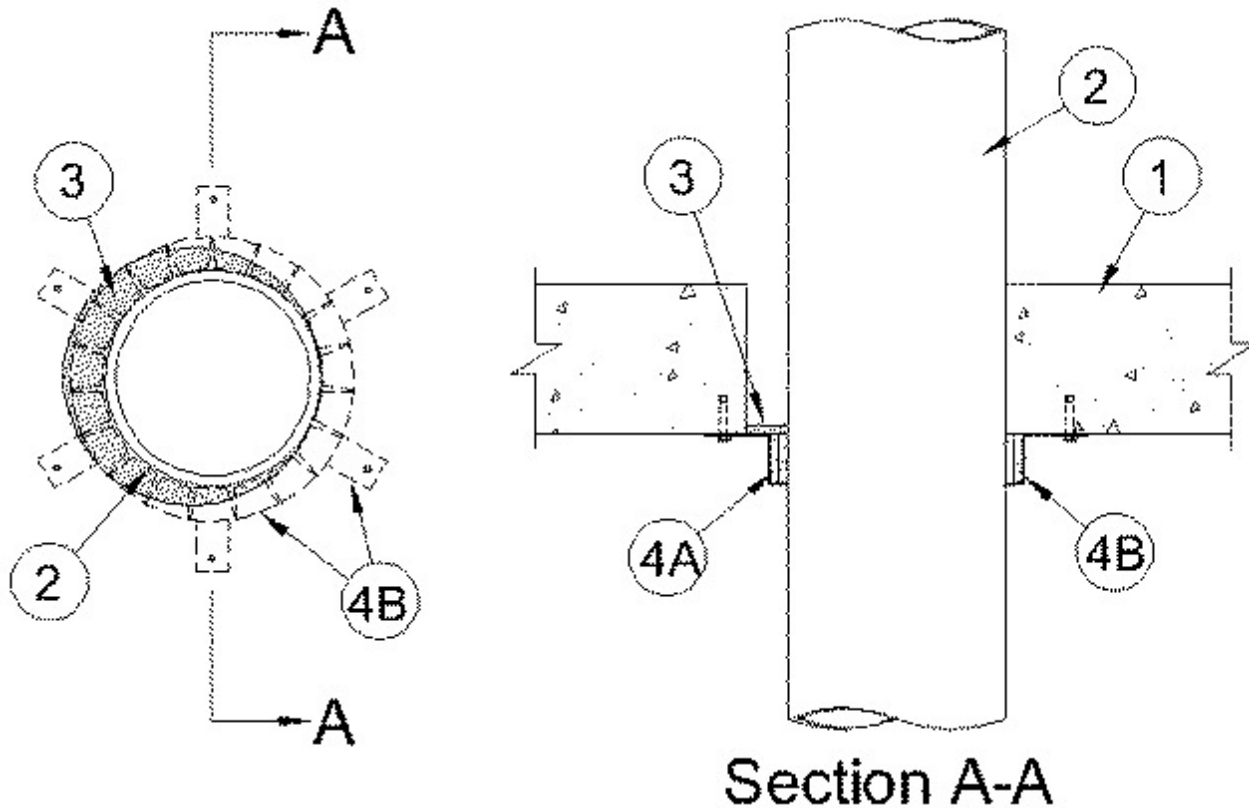

1. Floor or Wall Assembly — Min 4-1/2 in. (114 mm) thick reinforced lightweight or normal weight (100-150 pcf or 1600-2400 kg/m³) concrete. Wall may also be constructed of any UL Classified **Concrete Blocks**^{*}. Max diam of opening is 5 in. (127 mm).

See **Concrete Blocks** (CAZT) category in the Fire Resistance Directory for names of manufacturers.

2. Through Penetrants — One nonmetallic pipe to be installed either eccentrically or concentrically within the firestop system. The annular space shall be min 0 in. (point contact) to max 1/2 in. (13 mm). Pipe to be rigidly supported on both sides of floor or wall assembly. The following types and sizes of nonmetallic pipes may be used:

A. Polyvinyl Chloride (PVC) Pipe — Nom 4 in. (102 mm) diam (or smaller) Schedule 40 cellular or solid core PVC pipe for use in closed (process or supply) or vented (drain, waste or vent) piping systems.

B. Chlorinated Polyvinyl Chloride (CPVC) Pipe — Nom 4 in. (102 mm) diam (or smaller) SDR 13.5 or Schedule 40 CPVC pipe for use in closed (process or supply) piping systems. Schedule 40 CPVC pipe for use in vented (drain, waste or vent) piping systems.

C. Acrylonitrile Butadiene Styrene (ABS) Pipe — Nom 4 in. (102 mm) diam (or smaller) Schedule 40 cellular or solid core ABS pipe for use in closed (process or supply) or vented (drain, waste or vent) piping systems.

3. **Fill, Void or Cavity Materials* - Caulk** — Min 1/4 in. (6 mm) thickness of fill material applied within the annulus, flush with the bottom surface of floor or with both surfaces of wall.

RECTORSEAL — Metacaulk 1000 or Metacaulk 1200

W-Rating only applies when Metacaulk 1200 is used.

4. **Firestop System** — The firestop system shall consist of the following:

A. **Fill, Void or Cavity Materials* - Wrap Strip** — Nom 1/4 in. (6 mm) thick by 1 in. (25 mm) wide intumescent wrap strip. Two layers of wrap strip are individually wrapped around the through-penetrant with ends butted and held in place with masking tape. Butted ends in successive layer shall be offset. When diameter of penetrant is equal to or less than 3 in. (76 mm), one layer of wrap strip is wrapped around the through-penetrant with ends butted and held in place with masking tape. Wrap strips butted tightly against both surface of wall.

RECTORSEAL — Metacaulk Wrap Strip

B. **Steel Collar** — Collar fabricated from coils of precut 0.016 in. thick (No. 30 MSG) galv sheet steel available from wrap strip manufacturer. Collar shall be nom 1 in. (25 mm) deep with min 1 in. (25 mm) wide by 1-1/4 in. (32 mm) long anchor tabs on 4 in. (102 mm) centers for securement to underside of concrete floor and both sides of concrete wall. In addition, collar contains retainer tabs, 1/4 in. (6 mm) wide by 3/8 in. (10 mm) long located opposite the anchor tabs. Collar shall be wrapped over the wrap strip, with ends overlapping min 1 in. (25 mm) The retainer tabs are folded 90 deg towards the pipe to maintain the annular space around the pipe and to retain the wrap strip. Collar secured to bottom surface of the floor or both surfaces of wall at each anchor tab by means of min 1/4 in. (6 mm) diam by 1-1/4 in. (32 mm) long steel expansion bolts or steel Tapcon® concrete anchors in conjunction with 1/4 in. (6 mm) by 5/8 in. (16 mm) diam fender washers.

*Bearing the UL Classification Mark