



### System No. C-AJ-2113

December 20, 2000

F Rating — 3 Hr

T Rating — 1/2 Hr

L Rating At Ambient — 28 CFM/sq ft

L Rating At 400 F — Less Than 1 CFM/sq ft

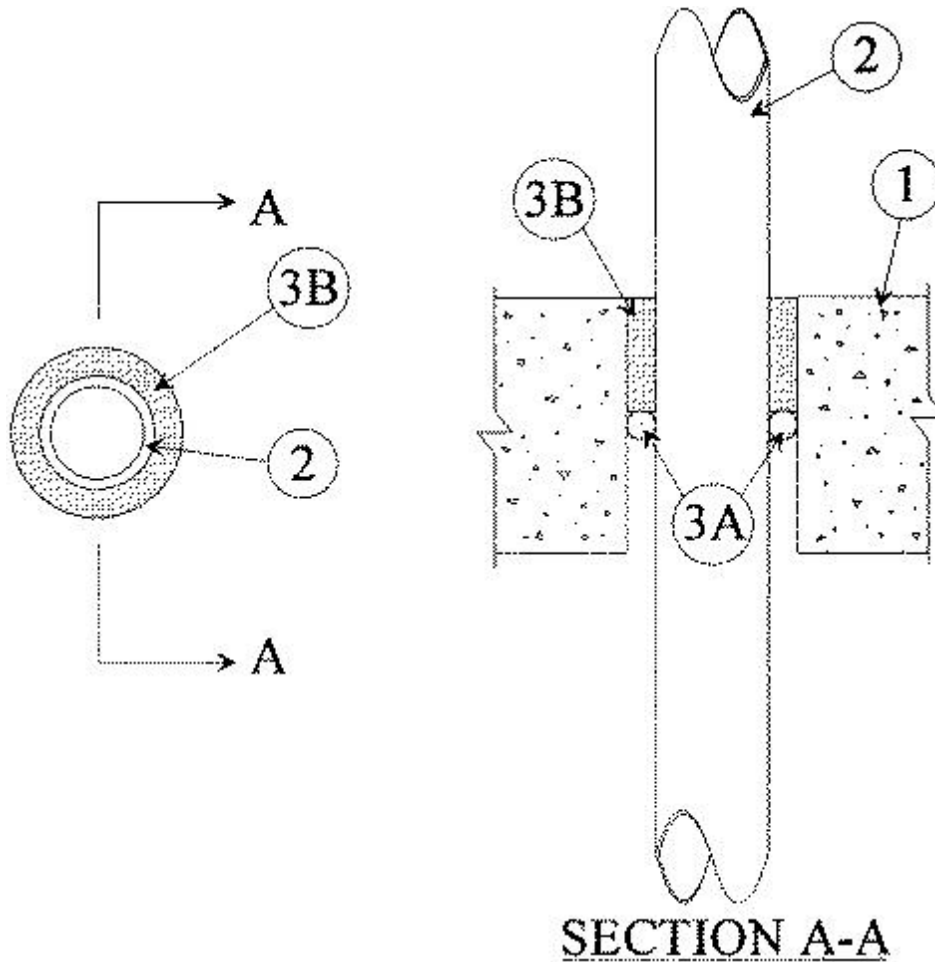

1. **Floor or Wall Assembly** — Min 4-1/2 in. thick reinforced lightweight or normal weight (100-150 pcf) concrete. Wall may also be constructed of any UL Classified **Concrete Blocks\***. Max diam of opening is 4 in.

See **Concrete Blocks** (CAZT) category in the Fire Resistance Directory for names of manufacturers.

2. **Nonmetallic Pipe** — One nonmetallic pipe to be centered within the firestop system. A nom annular space of 7/8 in. is required within the firestop system. Pipe to be rigidly supported on both sides of floor or wall assembly. The following types and sizes of nonmetallic may be used:

A. **Polyvinyl Chloride (PVC) Pipe** — Nom 2 in. diam (or smaller) Schedule 40 PVC pipe for use in closed (process or supply) or vented (drain, waste or vent) piping systems.

B. **Chlorinated Polyvinyl Chloride (CPVC) Pipe** — Nom 2 in. diam (or smaller) SDR 17 CPVC pipe for use in closed (process or supply) or vented (drain, waste or vent) piping systems.

3. **Firestop System** — The firestop system shall consist of the following:

A. **Packing Material** — (Optional) — Foam backer rod firmly packed into opening as a permanent form. Packing material to be recessed from top surface of floor or from both surfaces of wall as required to accommodate the required thickness of fill material.

B. **Fill, Void or Cavity Material\*** — **Sealant** — Min 2 in. thickness of fill material applied within the annulus, flush with top surface of floor or with both surfaces of wall.

**RECTORSEAL** — Metacaulk 1000.

\*Bearing the UL Classification Mark