



System No. C-AJ-1263

November 29, 1999

F Rating — 3 Hr

T Rating — 0 Hr

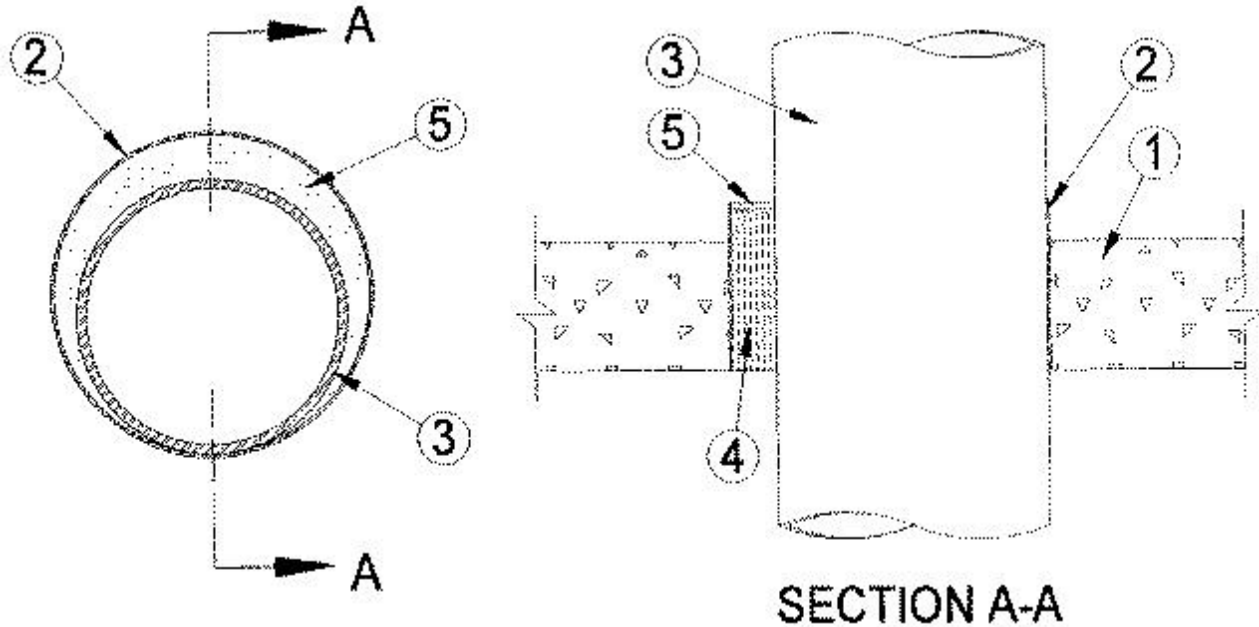

1. **Floor or Wall Assembly** — Min 4-1/2 in. thick reinforced lightweight or normal weight (100-150 pcf) concrete. Wall may also be constructed of any UL Classified **Concrete Blocks***.

See **Concrete Blocks** (CAZT) category for names of manufacturers.

2. **Steel Sleeve** — (Optional) nom 22 in. diam (or smaller) cylindrical sleeve formed from min 1/8 in. thick steel. Length of steel sleeve to be 1-1/2 in. greater than thickness of floor or 3 in. greater than thickness of wall. Steel sleeve to project 1-1/2 in. beyond top surface of floor or both sides of wall.

3. **Through Penetrant** — One metallic pipe or conduit to be installed either concentrically or eccentrically within the firestop system. The annular space between the through penetrant and the periphery of opening shall be min 0 in. (point contact) to a max of 1-3/4 in. Through penetrant to be rigidly supported on both sides of floor or wall assembly. The following types and sizes of metallic pipe or conduit may be used:

- A. **Steel Pipe** — Nom 20 in. diam (or smaller) Schedule 10 (or heavier) steel pipe.
- B. **Iron Pipe** — Nom 20 in. diam (or smaller) cast or ductile iron pipe.
- C. **Steel Conduit** — Nom 6 in. diam (or smaller) rigid steel conduit.
- D. **Copper Tube** — Nom 6 in. diam (or smaller) Type L (or heavier) copper tube.
- E. **Copper Pipe** — Nom 6 in. diam (or smaller) Regular (or heavier) copper pipe.

4. **Packing Material** — When optional steel sleeve is used, min 5-3/4 in. thickness of min 4 pcf mineral wool batt insulation firmly packed into annular space as a permanent form. When steel sleeve is not used, min thickness of mineral wool is 4-1/4 in. Packing material to be recessed min 1/4 in. from top of sleeve or concrete in floor or from both ends of sleeve or concrete in wall as required to accommodate the caulk fill material (Item 5).

5. **Fill, Void or Cavity Material* — Caulk** — When optional steel sleeve is used, fill material applied to fill the annular space to a min depth of 1/4 in. flush with the top edge of steel sleeve in floor or both ends of steel sleeve in wall. When optional steel sleeve is not used, fill material applied to a min depth of 1/4 in. flush with top surface of floor or with both surfaces of wall. A min 1/4 in. diam bead of caulk shall be applied to the edge of the steel sleeve or concrete where the

pipe or conduit is installed at point contact.

RECTORSEAL — Metacaulk 1000

*Bearing the UL Classification Mark