



System No. C-AJ-1261

October 17, 2007

F Rating — 3 Hr

T Rating — 0 Hr

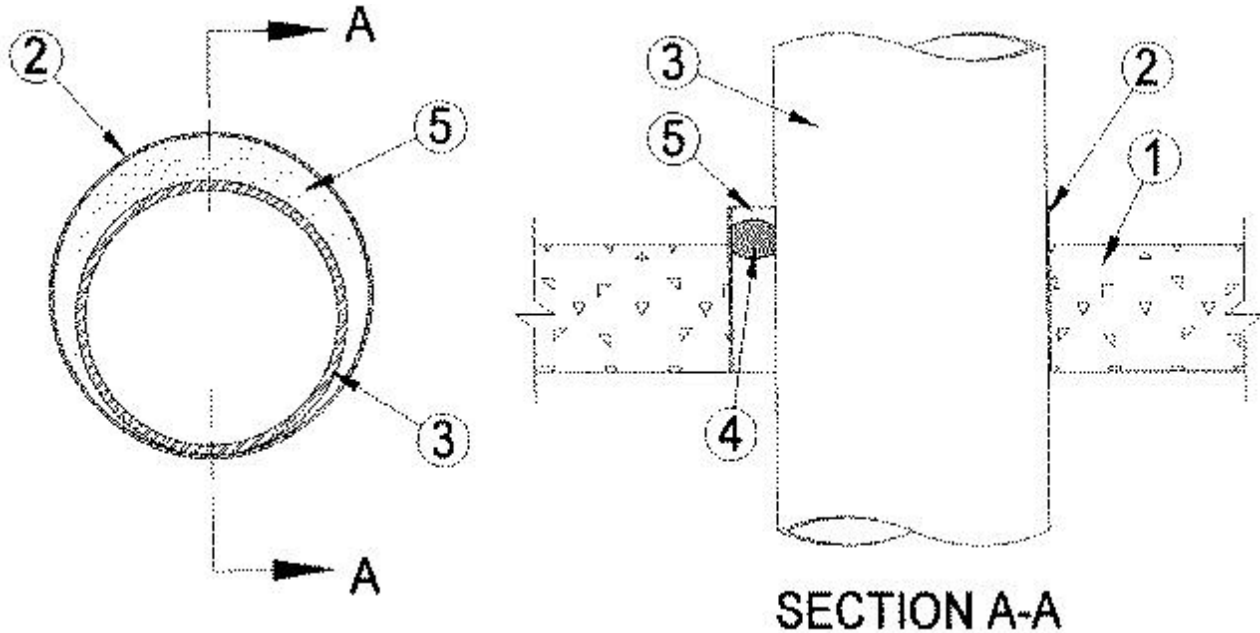

1. **Floor or Wall Assembly** — Min 4-1/2 in. (114 mm) thick reinforced lightweight or normal weight (100-150 pcf - 1600-2400 kg/m³) concrete. Wall may also be constructed of any UL Classified **Concrete Blocks***. Floor may also be constructed of any 6 in. (152 mm) thick UL Classified hollow-core Precast Concrete Units*.

See **Concrete Blocks** (CAZT) and **Precast Concrete Units** (CFTV) categories for names of manufacturers.

2. **Steel Sleeve** — (Optional for pipes 12 in. (305 mm) or smaller) - Nom 22 in. (559 mm) diam (or smaller) cylindrical sleeve formed from min 1/8 in. (3 mm) thick steel. Inside diam of steel sleeve to be min 1 in. (25 mm) greater than outside diam of through penetrant (Item 3). Length of steel sleeve to be 1-1/2 in. (38 mm) greater than thickness of floor or 3 in. (76 mm) greater than thickness of wall. Steel sleeve to project 1-1/2 in. (38 mm) beyond top surface of floor or both sides of wall. When precast concrete units are used, the sleeve shall not exceed nom 6 in. (152 mm) diam.

3. **Through Penetrant** — One metallic pipe or conduit to be installed either concentrically or eccentrically within the firestop system. The annular space between the through penetrant and the periphery of the steel sleeve shall be min 0 in. (point contact) to a max of 1-3/4 in. (44 mm). Through penetrant to be rigidly supported on both sides of floor or wall assembly. The following types and sizes of metallic pipe or conduit may be used:

- A. **Steel Pipe** — Nom 20 in. (508 mm) diam (or smaller) Schedule 10 (or heavier) steel pipe.
- B. **Iron Pipe** — Nom 20 in. (508 mm) diam (or smaller) cast or ductile iron pipe.
- C. **Steel Conduit** — Nom 6 in. (152 mm) diam (or smaller) rigid steel conduit.
- D. **Copper Tube** — Nom 6 in. (152 mm) diam (or smaller) Type L (or heavier) copper tubing.
- E. **Copper Pipe** — Nom 6 in. (152 mm) diam (or smaller) Regular (or heavier) copper pipe.

4. **Packing Material** — (Optional) — Polyethylene backer rod firmly packed into annular space as a permanent form. Packing material to be recessed min 1/2 in. (13 mm) from top of sleeve in floor or from both ends of sleeve in wall as required to accommodate the caulk fill material (Item 5).

5. **Fill, Void or Cavity Material*** — **Caulk** — For pipes larger than 12 in. (305 mm), applied to fill the annular space to a min depth of 1/2 in. (13 mm) flush with the top edge of steel sleeve in floor or both ends of steel sleeve in wall. For pipes 12

in. (305 mm) and less, sealant applied to fill the annular space to a min depth of 1/2 in. (13 mm) flush with the top edge of floor or both sides of wall. A min 1/4 in.(6 mm) diam bead of caulk shall be applied to the area of point contact with the wall or floor.

RECTORSEAL — Metacaulk 1000

*Bearing the UL Classification Mark