



System No. C-AJ-1221

November 29, 1995

F Rating — 3 Hr

T Rating — 1/4 Hr

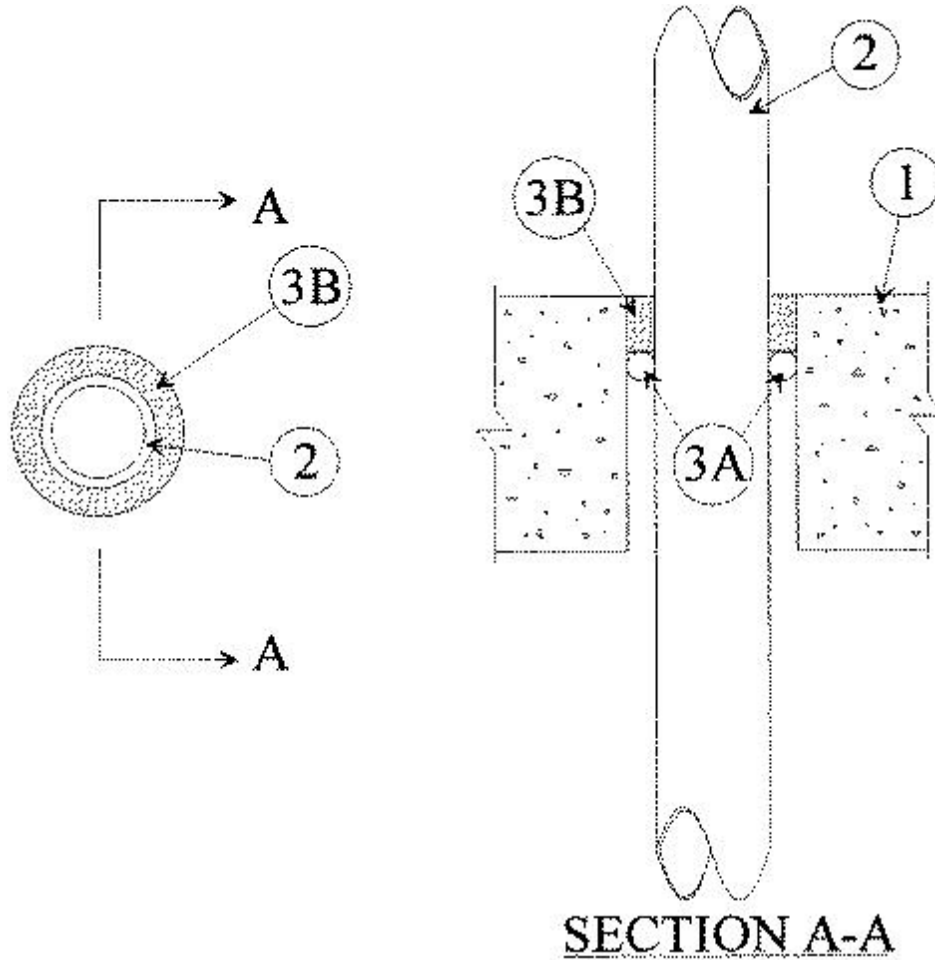

1. **Floor or Wall Assembly** — Min 4-1/2 in. thick reinforced lightweight or normal weight (100-150 pcf) concrete. Wall may also be constructed of any UL Classified **Concrete Blocks***. Max diam of opening is 6 in.

See **Concrete Blocks** (CAZT) category in the Fire Resistance directory for names of manufacturers.

2. **Through Penetrants** — One metallic pipe, conduit or tubing to be centered within the firestop system. Pipe, conduit or tubing to be rigidly supported on both sides of floor or wall assembly. The following types and sizes of metallic pipes, conduits or tubing may be used:

A. **Steel Pipe** — Nom 4 in. diam (or smaller) Schedule 40 (or heavier) steel pipe. A nom annular space of 3/4 in. is required within the firestop system.

B. **Conduit** — Nom 4 in. diam (or smaller) steel electrical metallic tubing or steel conduit. A nom annular space of 3/4 in. is required within the firestop system.

3. **Firestop System** — The firestop system shall consist of the following:

A. **Packing Material** — (Optional) — Foam backer rod firmly packed into opening as a permanent form. Packing material to be recessed from top surface of floor or from both surfaces of wall as required to accommodate the required thickness of fill material.

B. Fill, Void or Cavity Material* — Caulk — Min 3/4 in. thickness of fill material applied within the annulus, flush with top surface of floor or with both surfaces of wall.

RECTORSEAL — Metacaulk 1000

*Bearing the UL Classification Mark